

Clipper and Clamper

CM

Clippers/Limiters Using Diodes

Applications

➤ **Signal Conditioning:**

- Clippers are used in signal conditioning circuits to limit the amplitude of signals to a specific range. This ensures that the signal remains within acceptable levels for further processing or transmission.

➤ **Voltage Regulation:**

- In power supply circuits, clippers are employed to regulate the output voltage by clipping off voltage spikes or overshoots, thus maintaining a stable and controlled output.

➤ **Audio Signal Processing:**

- Clipping is used in audio applications to prevent audio signals from exceeding certain limits, avoiding distortion and protecting speakers or audio equipment from damage due to excessively high amplitudes.

➤ **Waveform Generation:**

- Clipping can be used to shape waveforms and generate square waves from sinusoidal signals. This is particularly useful in oscillator circuits and pulse-width modulation (PWM) applications.

➤ **Data Signal Processing:**

- In digital communication systems, clippers are utilized to limit the amplitude of data signals, ensuring that the transmitted data remains within the acceptable voltage range.

➤ **Analog-to-Digital Conversion:**

- In some analog-to-digital converter (ADC) applications, clippers can be used to preprocess analog signals before conversion, preventing any signal excursions that could exceed the ADC's dynamic range.

➤ **Noise Reduction:**

- Clippers can be employed in noise reduction circuits to remove or attenuate unwanted noise components from a signal. The noise is clipped off, and only the desired signal remains.

➤ **Protective Circuits:**

- In some electronic circuits, clippers act as protective components to prevent voltage spikes or transients from damaging sensitive components.

➤ **Overvoltage Protection:**

- In some electronic systems, clippers can be used as overvoltage protection to limit voltage levels and prevent damage to downstream components.

Classifications

- Clippers are electronic circuits used to clip or limit the amplitude of an input signal to a specified level. They utilize diodes or other non-linear devices to achieve this function. Based on their operation and the portion of the signal they clip.
- Clippers can be classified into several types:
 - **Series Diode Clipper**
 - **Positive Clipper**
 - **Negative clippers**
 - **Shunt Diode Clipper:**
 - **Positive Clipper:**
 - **Negative clippers**
 - **Biased clipper:**
 - **Dual Clipper:**
 - **Three-Level Clipper:**

Series Diode Clipper

- This type of clipper uses a diode in series with the input signal.
- It clips the positive or negative portion of the signal, allowing only the other portion to pass through.
- Output is obtained across the diode in the clipped region.

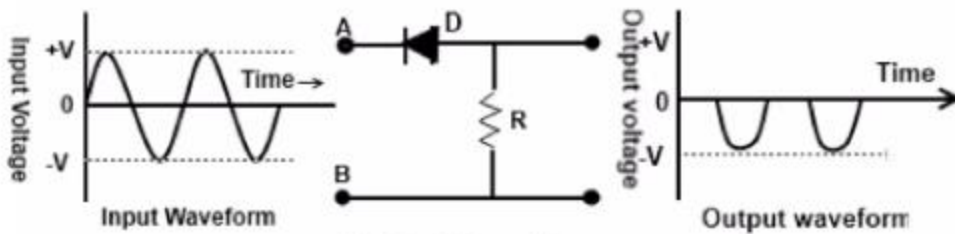

(a) Positive clipper

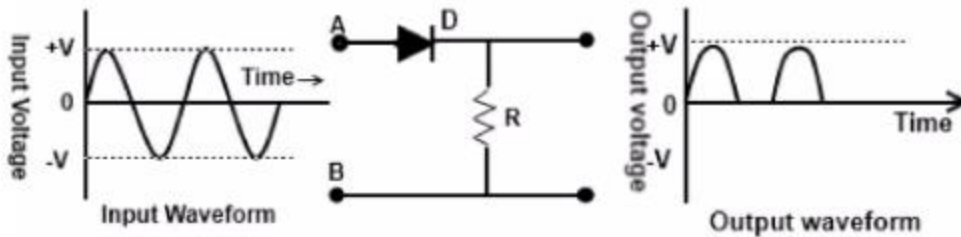

(b) Negative clipper

Negative series clipper

$$V_L = V_{in} - 0.7 \text{ V} \quad \text{for positive } V_{in}$$

$$V_L = 0 \text{ V} \quad \text{for negative } V_{in}$$

Positive series clipper

$$V_L = 0 \text{ V} \quad \text{for positive } V_{in}$$

$$V_L = -V_{in} + 0.7 \text{ V} \quad \text{for negative } V_{in}$$

Shunt Diode Clipper

- This clipper employs a diode in parallel (shunt) with the input signal.
- It clips either the negative or positive portion of the signal, allowing only the other portion to pass through.
- Output is taken across the load resistor connected in parallel with the diode.

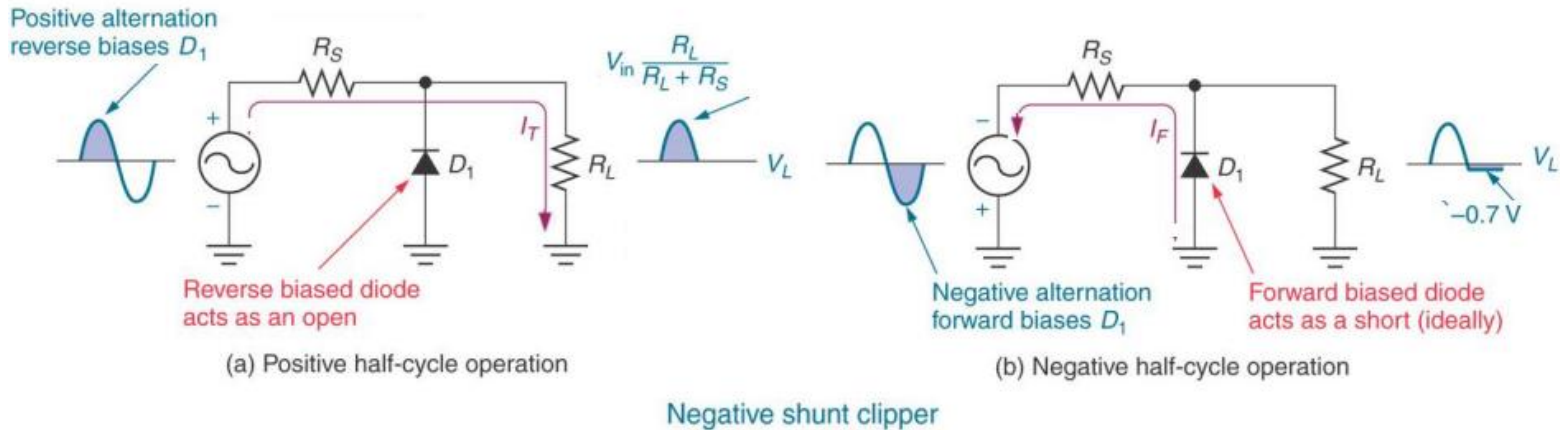
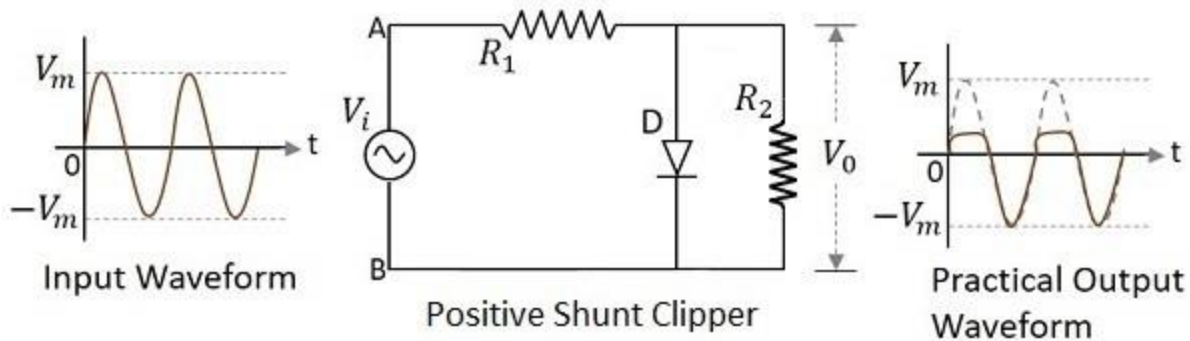

Biased Clipper:

- A biased clipper uses a dc biasing source to set the limit on the output voltage.
- The additional bias voltage allows the circuit to clip the input waveforms at certain values other than V_F of 0.7 V

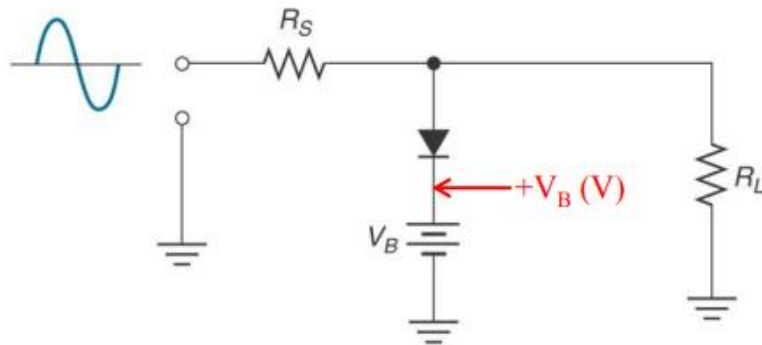

(a) Positive-biased clipper

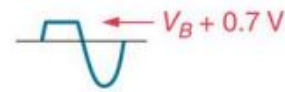

Positive-biased clipper clips its input signal at $V_B + 0.7 \text{ V}$.

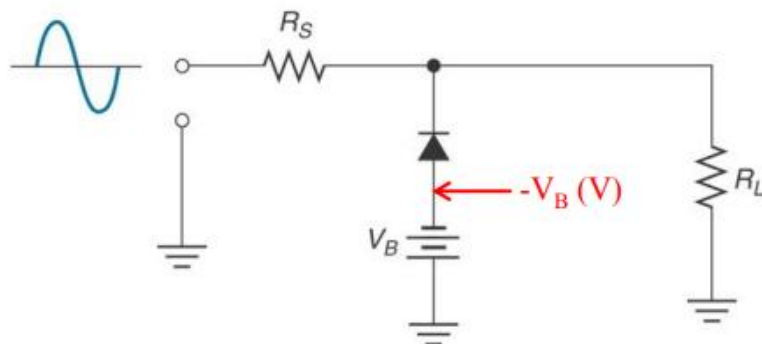

(b) Negative-biased clipper



Negative-biased clipper clips its input signal at $-V_B - 0.7 \text{ V}$.

Dual Clipper:

- The dual clipper combines both series and shunt clippers.
- It utilizes two diodes to clip both the positive and negative portions of the signal.
- The output is limited to a specified range between the two clipping levels.

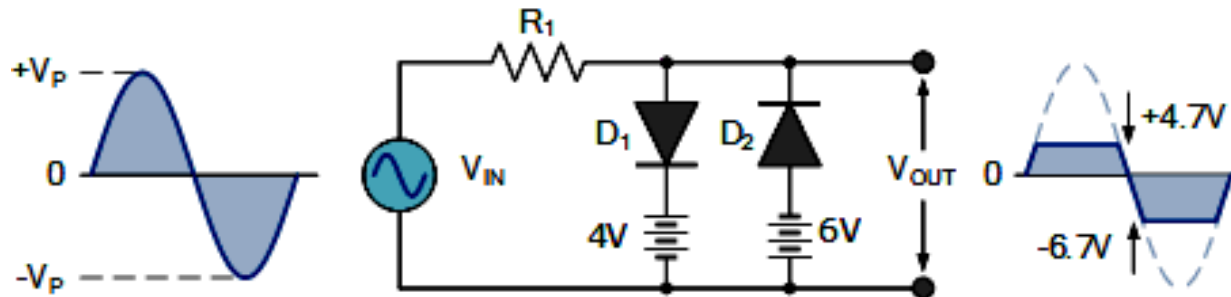

Clampers

Clampers

- Diode clampers are widely used in television receiver and FM (frequency modulation) transmitters, where the variable frequency interference can be removed by using clamping method.
- **Diode Clampers**
- A clamper adds a dc level to an ac voltage. **Clampers** are sometimes known as *dc restorers*. Figure 46 shows a diode clamper that inserts a positive dc level in the output waveform.
- The shape of the input signal of a clamper is not changed.

Positive clamper

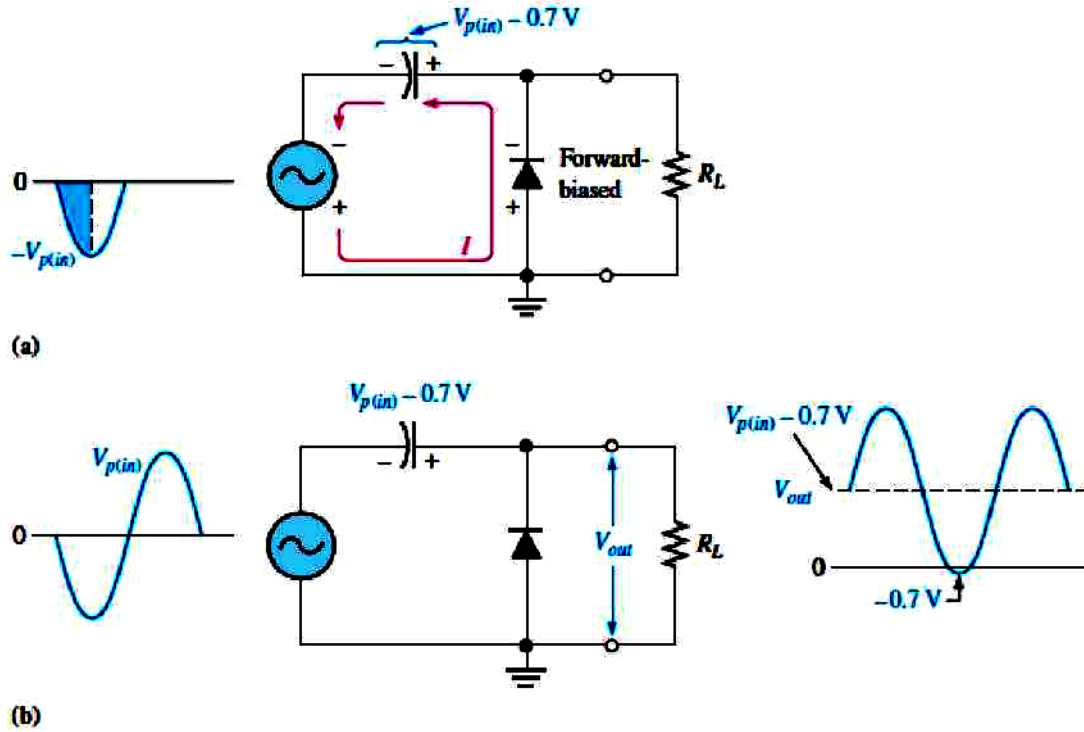

Operation

- The operation of this circuit can be seen by considering the first negative half-cycle of the input voltage. When the input voltage initially goes negative, the diode is forward biased, allowing the capacitor to charge to near the peak of the input ($V_p(in) - 0.7 \text{ V}$), as shown in Figure (a).
- Just after the negative peak, the diode is reverse-biased. This is because the cathode is held near ($V_p(in) - 0.7 \text{ V}$) by the charge on the capacitor.
- The capacitor can only discharge through the high resistance of RL .
- For a good clamping action the RC time constant should be at least 10 times of the period of the input frequency.
- The capacitor voltage acts as a battery in series with the input voltage, the dc voltage of the capacitor adds to the input voltage.

If the diode is turned around, a negative dc voltage is added to the input voltage to produce the output voltage as shown in Figure .

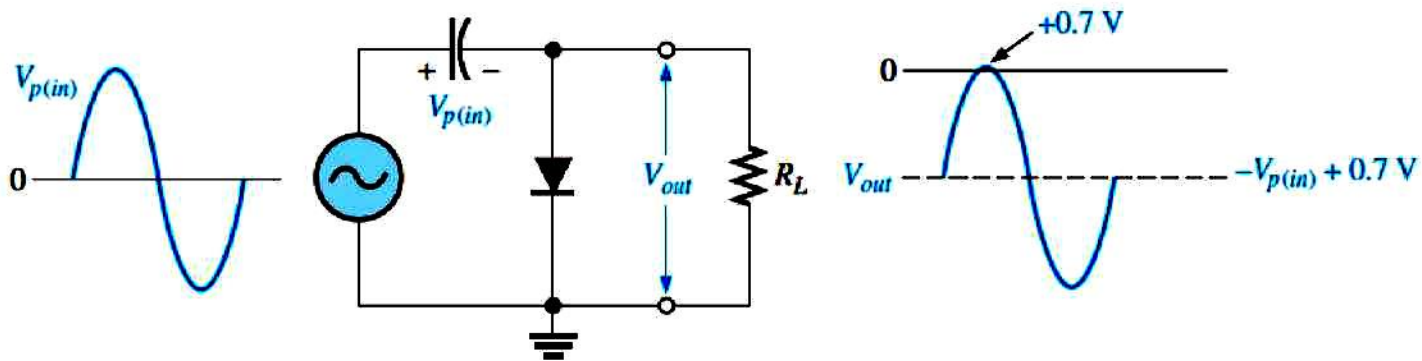

Example:

What is the output voltage that you would expect to observe across R_L in the clamping circuit of Figure below? Assume that RC is large enough to prevent significant capacitor discharge.

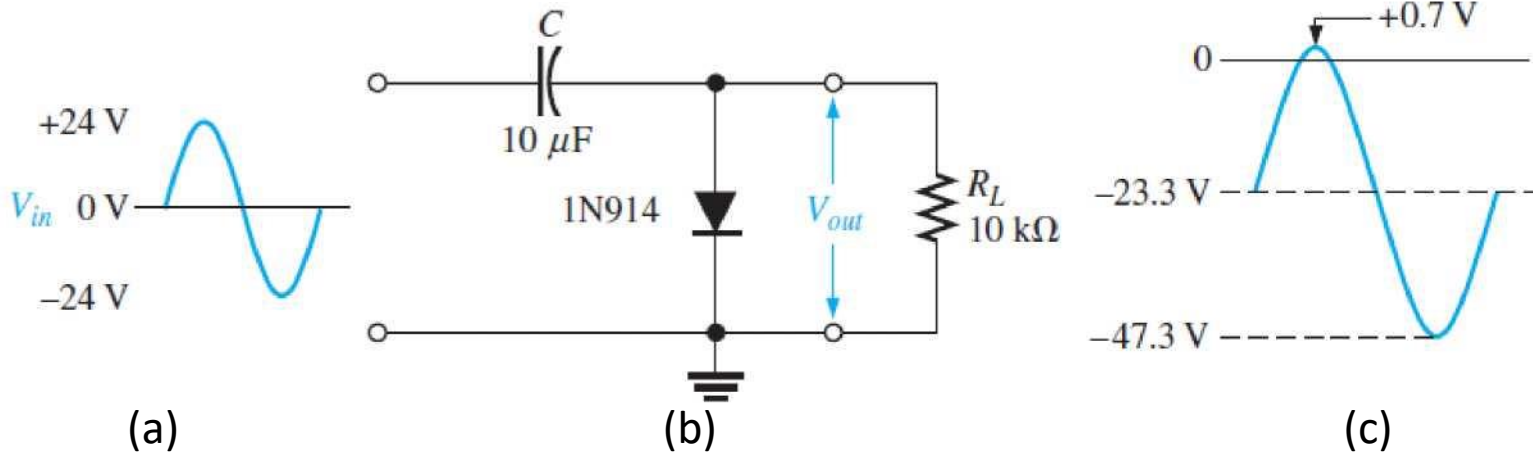

Solution Ideally, a negative dc value equal to the input peak less the diode drop is inserted by the clamping circuit,

$$V_{DC} = -(V_p - 0.7 \text{ V}) = -(24 \text{ V} - 0.7 \text{ V}) = -23.3 \text{ V}$$

Actually, the capacitor will discharge slightly between peaks, and, as a result, the output voltage will have an average value of slightly less than that calculated above. The output waveform goes to approximately +0.7 V. as shown in Figure (c)

Voltage Doubler

Applications

- Ion pumps
- Television CRT
- X-Ray systems
- Copy machine
- Radar equipment
- Travelling wave tubes etc.

Advantages

- Can replace the expensive and heavy transformers.
- Negative voltage can also be created by reversing the polarity of the connected diodes and capacitors.
- Can increase the voltage multiplication factor by cascading the similar voltage multipliers.

Half Wave Voltage Doubler

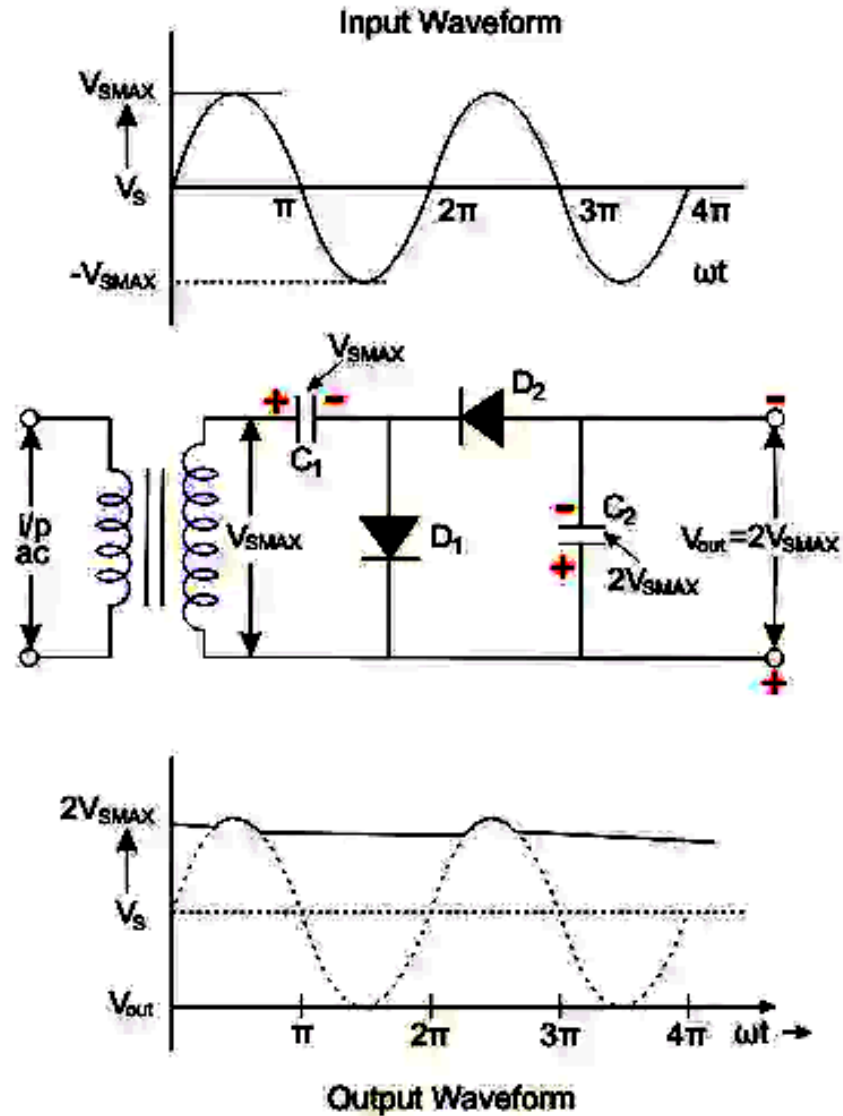

Working

- All over the positive half cycle of the AC sine wave, the first diode (D_1) is conducting D_2 is OFF.
- Capacitor (C_1) will be charged to the peak value of AC secondary voltage of transformer ($V_{S_{MAX}}$).
- This capacitor is unable to get discharged due to the unavailability of a path. So, it will remain in a fully charged condition.
- Next, all over the negative half cycle, the second diode (D_2) is conducting or forward biased state, and the first diode (D_1) is non-conducting or in the reversed biased state.
- The reversed biased diode (D_1) will block the discharging of the connected capacitor (C_1), and the forward-biased diode (D_2) will charge the connected capacitor (C_2).
- Here we can apply Kirchoff's voltage law to the outer loop, which starts from the bottom of the secondary of the transformer (the lower end is negative and the top end is in positive polarity) in the clockwise direction.

$$-V_{S_{MAX}} - V_{C_1} + V_{C_2} = 0$$

$$\therefore V_{C_2} = V_{S_{MAX}} + V_{C_1}$$

$$\text{We know that } V_{C_1} = V_{S_{MAX}}$$

the voltage across the capacitor; C_2 will be equal to, $V_{C_2} = V_{S_{MAX}} + V_{S_{MAX}} = 2V_{S_{MAX}}$

Working

- Throughout the next positive half cycle of AC input, the second diode (D_2) will be open due to the reversed biased condition. So, the second capacitor (C_2) will get discharged through the load and the output voltage (V_{out}) $< 2V_{SMAX}$.
- Otherwise, the two capacitors will be in the charged condition as said above. If there is a load, then in the next cycle, the C_2 will get recharged again.

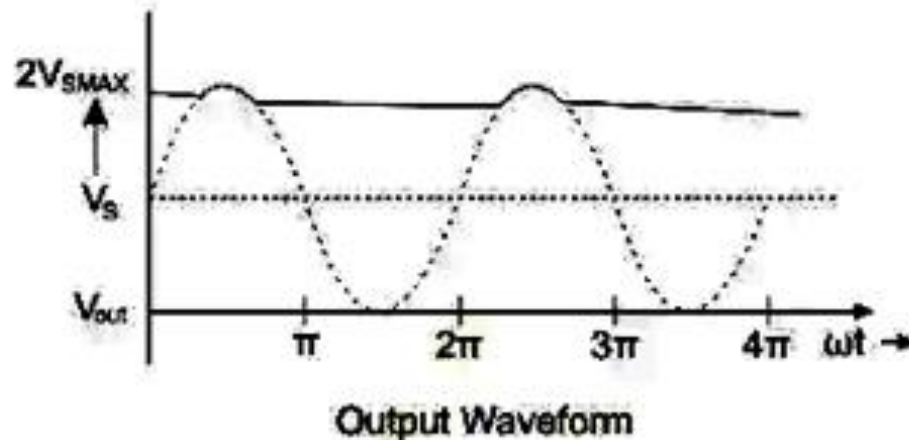

Full Wave Voltage Doubler

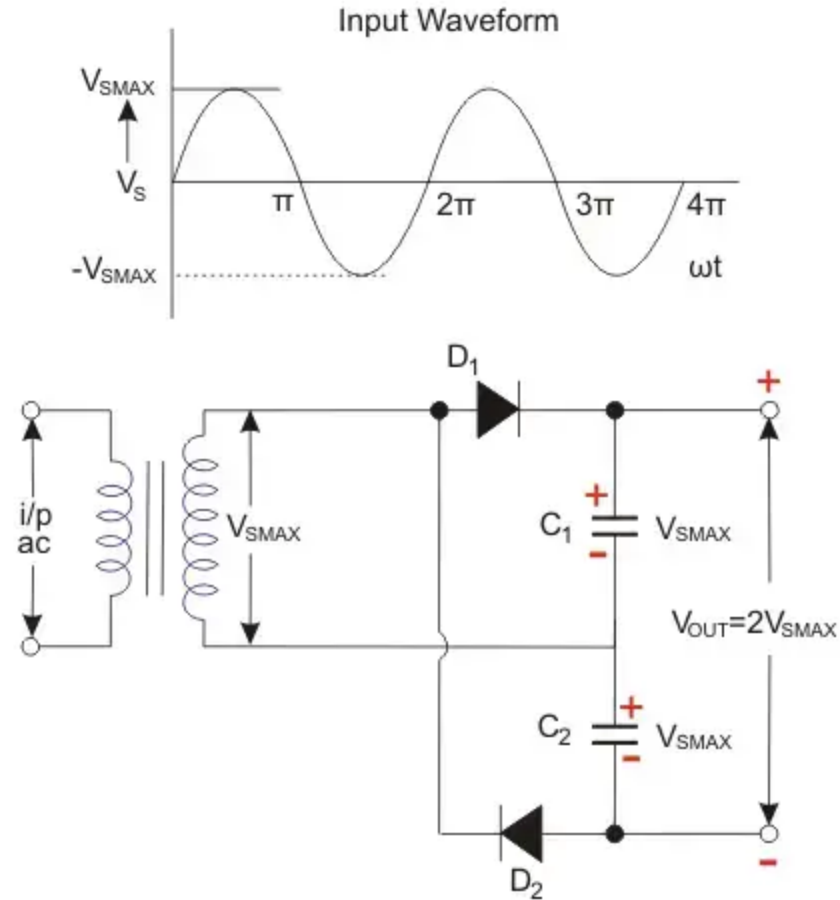

Working

- In this doubler, right through the positive cycle of input AC voltage, the first diode (D_1) is in the conducting state.
- That is a forward biased state, and it will charge the connected capacitor (C_1) equal to the peak value of AC secondary voltage of transformer ($V_{S\text{MAX}}$).
- At this time, D_2 will be in reverse biased condition or non-conducting state. Throughout the negative cycle of input AC voltage, the second diode (D_2) will be in forwarding biased state, and the second capacitor (C_2) gets charged.

$$V_{C1} + V_{C2} = 2V_{S\text{MAX}}$$

- In the no-load condition, the entire voltages of two capacitors are delivered as the output voltage.
- If there is some load connected across the output terminals, then output voltage ($V_{\text{out}} < 2V_{S\text{MAX}}$). The output waveform is shown below.

Output Waveform

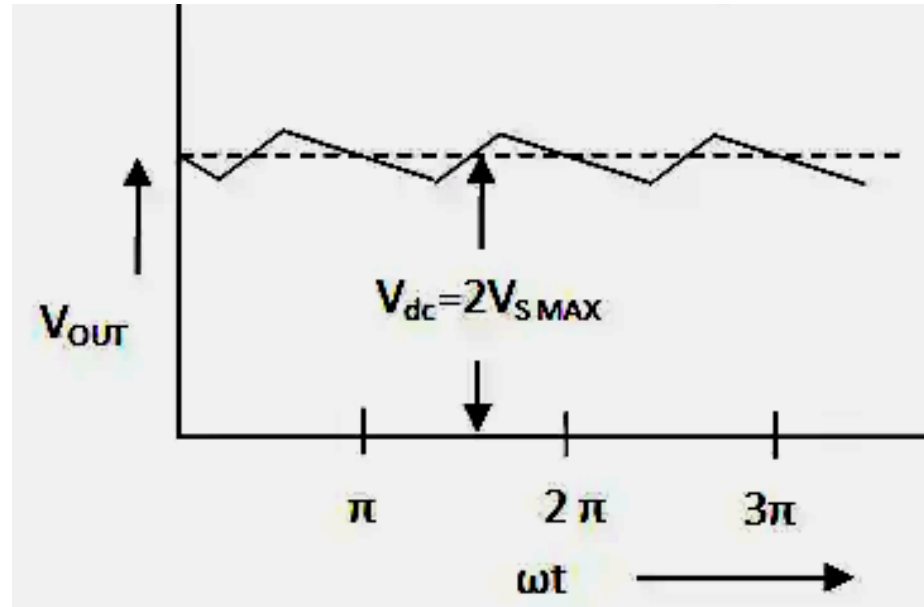

We can observe that both the voltage doubler will provide $2V_{S MAX}$ as the output. There is no need for a centre-tapped transformer. $2V_{S MAX}$ will be the peak inverse voltage ratings of the circuit diodes.

Voltage quadrupler

Voltage quadrupler

