

# Analog Circuit II

Dr. Chandrima Mondal (CM)

Assistant Professor

Dept. of ETCE, JU

**ANALOG CIRCUITS-II**  
ET/PC/B/T/215  
**3Pds/Wk Credit-3 (34L)**

## **Syllabus**

- **Recap: (1L)**
- **Multistage amplifiers:** cascaded BJT and FET amplifiers, frequency response of R-C coupled multistage amplifier. **(5L)**
- **Power amplifiers:** Analysis and design of class A, class B, class AB, class C, class D amplifiers. Design of heat sink, IC power amplifiers. **(6L)**
- **Tuned amplifiers:** bandwidth consideration of tuned amplifiers, analysis of single and double tuned amplifiers, stagger tuning, Butter worth and Chebyshev response. **(4L)**
- **Feedback concepts:** connection types, practical circuits, phase and frequency considerations. **(2L)**
- **Waveform generators:** oscillation criteria and oscillator circuits, variable frequency LC and RC sine wave oscillators, Phase shift oscillator, Wien-bridge oscillator, colpitts oscillator, Hartley oscillator and clapp oscillator and crystal oscillators, Blocking oscillator, relaxation oscillator, **(6L)**
- **Multivibrators:** their classification and implementation using BJT, OPAMP and 555 timers, 555 timer as variable duty cycle square wave generator, **(6L)**
- 
- **Linear time base circuits:** PLL-architecture and applications, VCO architecture and applications, synchronization and frequency division circuits. **(4L)**

# Course outcomes

- Describe and classify various amplifiers, oscillators and waveform generators. [K2, A1, A2]
- Explain working principle of PLL and study their applications. [K2, K3, A1, A2]
- Formulate and analyze various analog electronic circuits. [K4, K5, A3, S4]
- design analog electronic circuit to meet specific output and justify. [K5, K6, A4, A5]

# Book/References

- **Text books:**

- J. Millman, C. Halkias and S. Jit, "Electronic Devices and Circuits", Tata McGraw-Hill, 4th edition, 2015.
- Millman's Pulse, digital and switching waveforms
- Adel S. Sedra and Kenneth C. Smith, "Microelectronic Circuits-Theory and applications", seventh Edition , 2017
- Thomas L. Floyd, David M. Buchla, "Fundamentals of Analog Circuits", Pearson, 2nd Edn

- **Reference books:**

- D. A. Neaman, "Electronic Circuits: Analysis And Design", 3rd Edition", Tata McGraw-Hill, 2010
- Donald Schilling and Charles Belove, "Electronic Circuits: Discrete & Integrated", Tata McGraw-Hill Education 2002
- Robert L. Boylestad, Louis Nashelsky, "Electronic Devices and Circuit Theory " Pearson; 10 edition 2009

# Recap of CE, CB, CC amplifiers

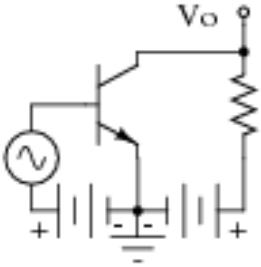
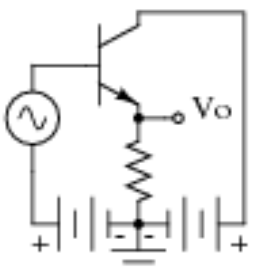
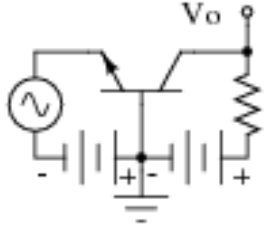
Basic circuit	Common emitter	Common collector	Common base
			
Voltage gain	high	less than unity	high, same as CE
Current gain	high	high	less than unity
Power gain	high	moderate	moderate
Phase inversion	yes	no	no
Input impedance	moderate $\approx 1\text{ k}$	highest $\approx 300\text{ k}$	low $\approx 50\ \Omega$
Output impedance	moderate $\approx 50\text{ k}$	low $\approx 300\ \Omega$	highest $\approx 1\text{ Meg}$

# Transistor configurations and their hybrid model

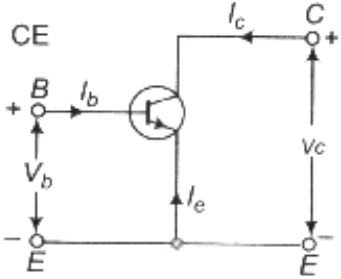
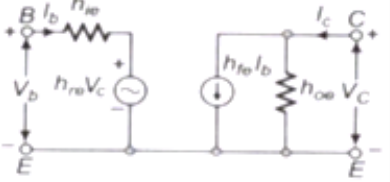
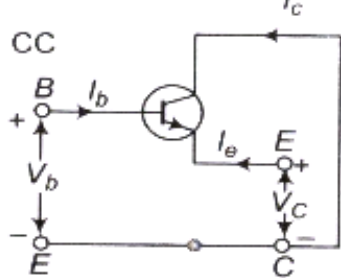
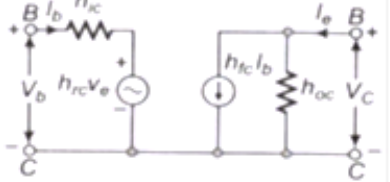
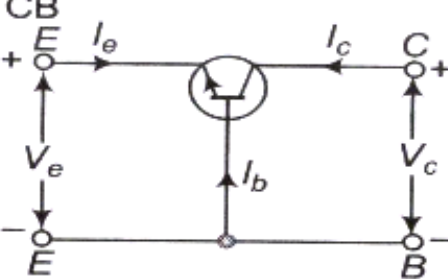
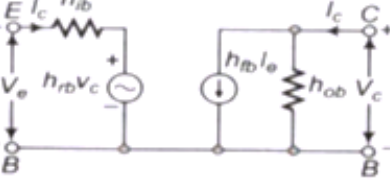
Circuit Schematic	Hybrid Model	Equations
<p>CE</p> 		$V_b = h_{ie} I_b + h_{re} V_c$ $I_c = h_{fe} I_b + h_{oe} V_c$
<p>CC</p> 		$V_b = h_{ie} I_b + h_{re} V_e$ $I_e = h_{fe} I_b + h_{oe} V_e$
<p>CB</p> 		$V_e = h_{ib} I_e + h_{re} V_c$ $I_c = h_{fb} I_e + h_{ob} V_c$

# Characteristics of CE, CB, CC amplifiers

Characteristics of BJT Amplifiers					
	$R_{in}$	$A_{vo}$	$R_o$	$A_v$	$G_v$
Common emitter	$(\beta + 1)r_e$	$-g_m R_C$	$R_C$	$-g_m(R_C \parallel R_L)$ $-\alpha \frac{R_C \parallel R_L}{r_e}$	$-\beta \frac{R_C \parallel R_L}{R_{sig} + (\beta + 1)r_e}$
Common emitter with $R_e$ (Fig. 7.38)	$(\beta + 1)(r_e + R_e)$	$-\frac{g_m R_C}{1 + g_m R_e}$	$R_C$	$\frac{-g_m(R_C \parallel R_L)}{1 + g_m R_e}$ $-\alpha \frac{R_C \parallel R_L}{r_e + R_e}$	$-\beta \frac{R_C \parallel R_L}{R_{sig} + (\beta + 1)(r_e + R_e)}$
Common base	$r_e$	$g_m R_C$	$R_C$	$g_m(R_C \parallel R_L)$ $\alpha \frac{R_C \parallel R_L}{r_e}$	$\alpha \frac{R_C \parallel R_L}{R_{sig} + r_e}$
Emitter follower	$(\beta + 1)(r_e + R_L)$	1	$r_e$	$\frac{R_L}{R_L + r_e}$	$\frac{R_L}{R_L + r_e + R_{sig}/(\beta + 1)}$ $G_{vo} = 1$ $R_{out} = r_e + \frac{R_{sig}}{\beta + 1}$
Setting $\beta = \infty$ ( $\alpha = 1$ ) and replacing $r_e$ with $1/g_m$ , $R_C$ with $R_D$ , and $R_e$ with $R_s$ results in the corresponding formulas for MOSFET amplifiers					

# Common Emitter Amplifier

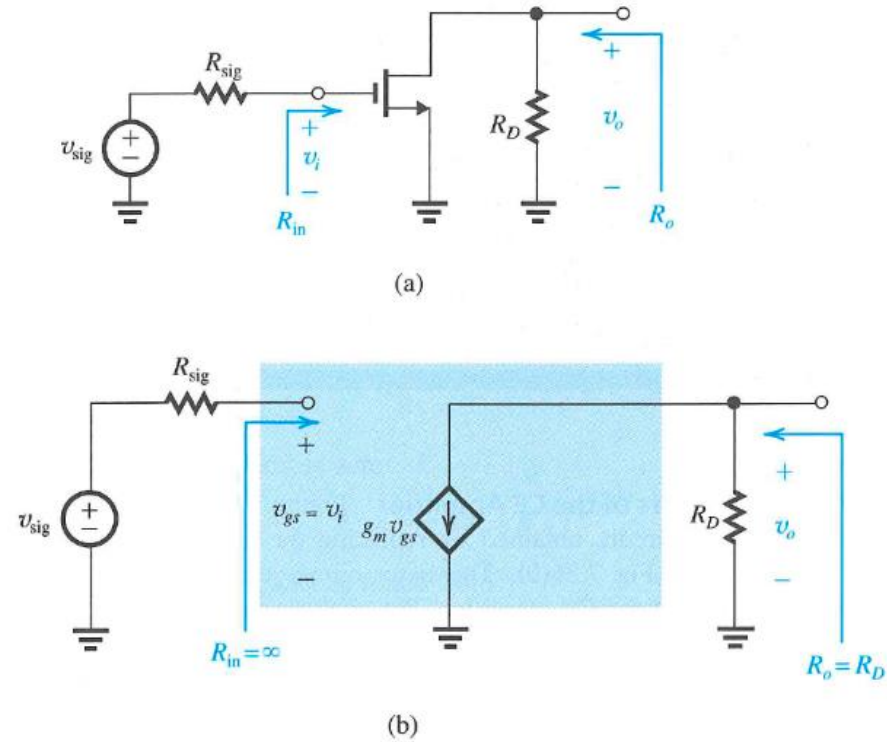

Figure 1: (a) Small-signal model for a common-source amplifier. (b) The hybrid- $\pi$  model for the common-source amplifier (Courtesy of Sedra and Smith).

# Common emitter Amplifier with a source resistance

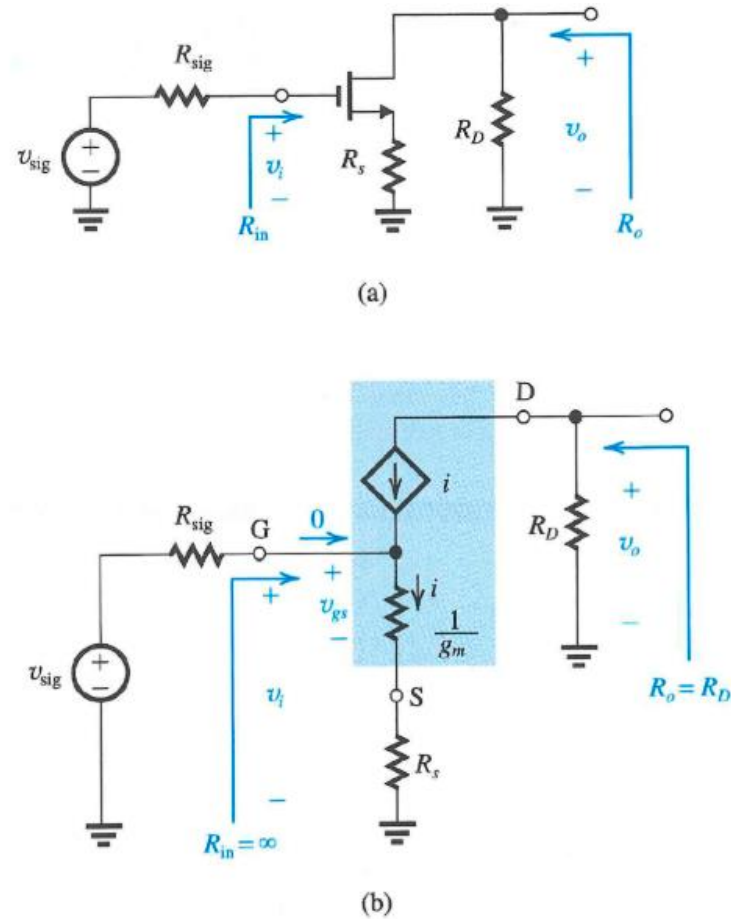

Figure 2: A CS amplifier with a source resistance: (top) detail circuit, and (bottom) equivalent circuit T model (Courtesy of Sedra and Smith).

# Common Gate Amplifier

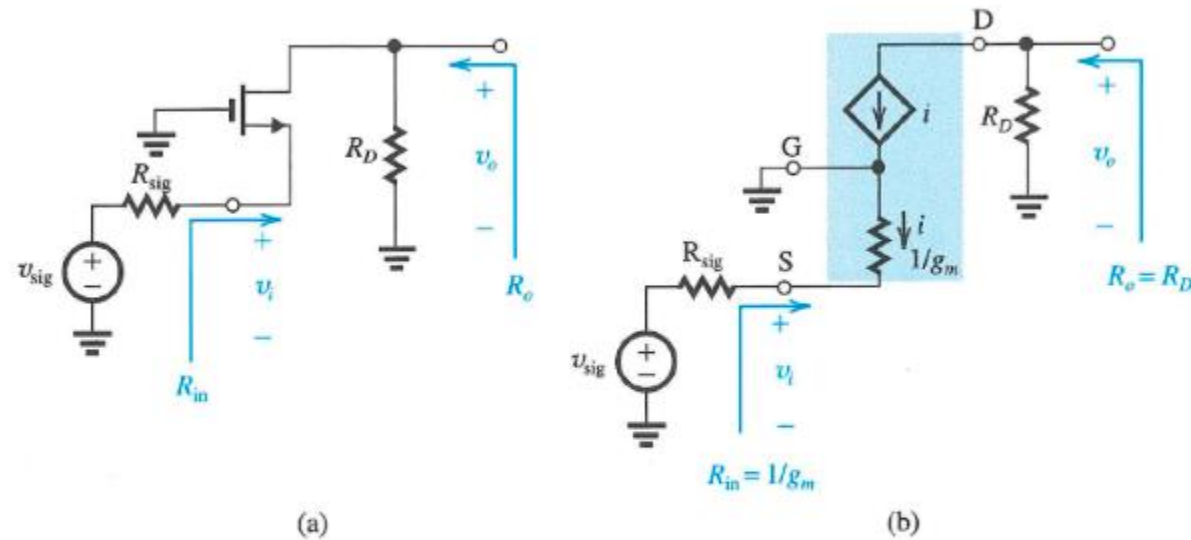

Figure 3: (a) Small-signal model for a common-gate amplifier. (b) The T model equivalent circuit for the common-gate amplifier. Note that the gate current is always zero in the T model (Courtesy of Sedra and Smith).

# Common Drain Amplifier/Source follower

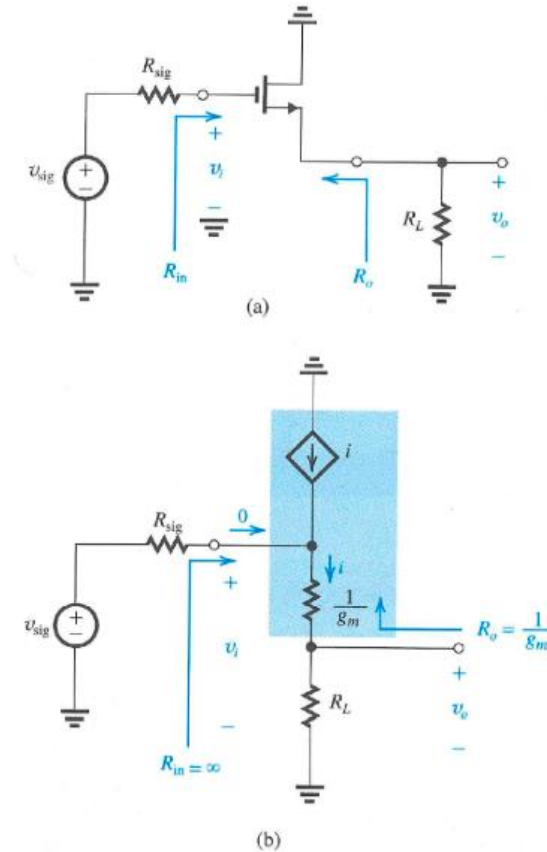

Figure 4: (a) Common-drain MOSFET amplifier or source follower for small signals. (b) The T model equivalent circuit for the common-drain or source follower amplifier. Note that the gate current is always zero in this model (Courtesy of Sedra and Smith).

# Characteristics of CS, CG, CD amplifiers

Amplifier type	Characteristics <sup>a</sup>				
	$R_{in}$	$A_{v_{no}}$	$R_o$	$A_v$	$G_v$
Common source (Fig. 7.35)	$\infty$	$-g_m R_D$	$R_D$	$-g_m (R_D \parallel R_L)$	$-g_m (R_D \parallel R_L)$
Common source with $R_s$ (Fig. 7.37)	$\infty$	$-\frac{g_m R_D}{1 + g_m R_s}$	$R_D$	$\frac{-g_m (R_D \parallel R_L)}{1 + g_m R_s}$ $-\frac{R_D \parallel R_L}{1/g_m + R_s}$	$-\frac{g_m (R_D \parallel R_L)}{1 + g_m R_s}$ $-\frac{R_D \parallel R_L}{1/g_m + R_s}$
Common gate (Fig. 7.39)	$\frac{1}{g_m}$	$g_m R_D$	$R_D$	$g_m (R_D \parallel R_L)$	$\frac{R_D \parallel R_L}{R_{sig} + 1/g_m}$
Source follower (Fig. 7.42)	$\infty$	1	$\frac{1}{g_m}$	$\frac{R_L}{R_L + 1/g_m}$	$\frac{R_L}{R_L + 1/g_m}$

**Table 11-2** Typical quantities for basic *FET* and *BJT* circuits

<i>FET</i> circuit	$A_v$	$Z_i$	$Z_o$	<i>BJT</i> circuit	$A_v$	$Z_i$	$Z_o$
CS	-25	500 k $\Omega$	5 k $\Omega$	CE	-250	5 k $\Omega$	5 k $\Omega$
CD	$\approx 1$	500 k $\Omega$	200 $\Omega$	CC	$\approx 1$	5 k $\Omega$	20 $\Omega$
CG	25	200 $\Omega$	5 k $\Omega$	CB	250	20 $\Omega$	5 k $\Omega$