

Digital Image Processing

Image Enhancement in Frequency Domain

Prof. Sheli Sinha Chaudhuri

Department of Electronics and Telecommunication Engineering
Jadavpur University



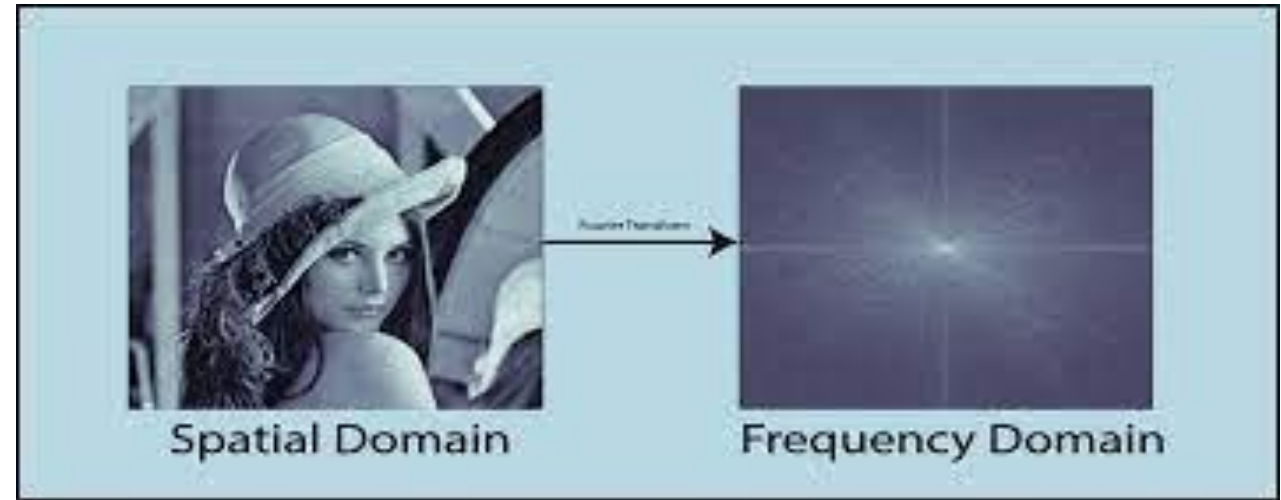
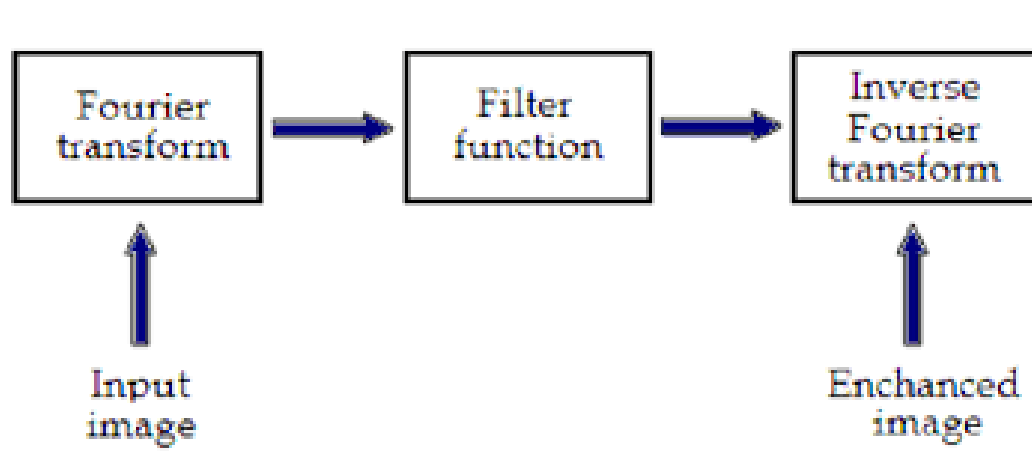

Chapter 4

Lecture 5/6: Image Enhancement in Frequency Domain



Contents

- Sampling and the Fourier Transform of Sampled Functions
- DFT of One Variable
- Extension to Functions of Two Variables
- Some Properties of the 2-D Discrete Fourier Transform
- Basics of Filtering in the Frequency Domain
- Image Smoothing using Frequency Domain Filters
- Image Sharpening using Frequency Domain Filters
- Selective Filtering



Signals in Frequency Domain

- Any function that **periodically** repeats itself can be expressed as the **sum** of sines and/or cosines of different frequencies, each multiplied by a different coefficient (**Fourier series**).
- Even functions that are **not periodic** (but whose area under the curve is finite) can be expressed as the **integral** of sines and/or cosines multiplied by a weighting function (**Fourier transform**).



Signals in Frequency Domain

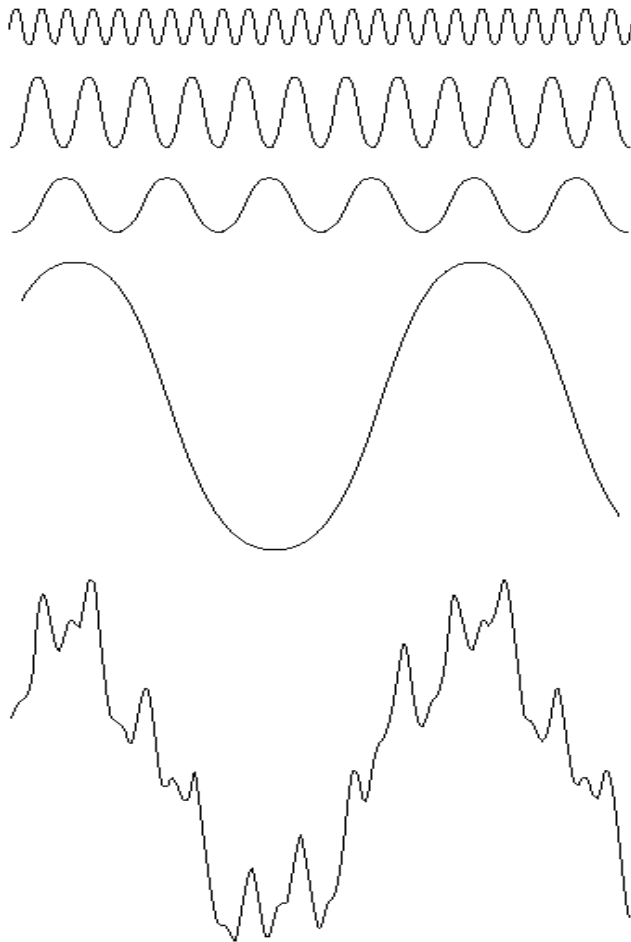

FIGURE 4.1 The function at the bottom is the sum of the four functions above it. Fourier's idea in 1807 that periodic functions could be represented as a weighted sum of sines and cosines was met with skepticism.

The **frequency domain** refers to the plane of the two dimensional discrete Fourier transform of an image.

The purpose of the Fourier transform is to represent a signal as a linear combination of sinusoidal signals of various frequencies.



Signals in Frequency Domain

- The **one-dimensional** Fourier transform and its inverse

- Fourier transform (**continuous case**)

$$F(u) = \int f(x) e^{-j2\pi ux} dx \quad \text{where } j = \sqrt{-1}$$

- Inverse Fourier transform:

$$f(x) = \int F(u) e^{j2\pi ux} du \quad e^{j\theta} = \cos \theta + j \sin \theta$$

- The **two-dimensional** Fourier transform and its inverse

- Fourier transform (**continuous case**)

$$F(u, v) = \int \int f(x, y) e^{-j2\pi(ux+vy)} dx dy$$

- Inverse Fourier transform:

$$f(x, y) = \int_{-\infty}^{\infty} \int_{-\infty}^{\infty} F(u, v) e^{j2\pi(ux+vy)} dudv$$



Signals in Frequency Domain

- The **one-dimensional** Fourier transform and its inverse
 - Fourier transform (**discrete case**) DTC

$$F(u) = \frac{1}{M} \sum_{x=0}^{M-1} f(x) e^{-j2\pi ux/M} \quad \text{for } u = 0, 1, 2, \dots, M-1$$

- Inverse Fourier transform:

$$f(x) = \sum_{u=0}^{M-1} F(u) e^{j2\pi ux/M} \quad \text{for } x = 0, 1, 2, \dots, M-1$$



Signals in Frequency Domain

- Since $e^{j\theta} = \cos \theta + j \sin \theta$ and the fact $\cos(-\theta) = \cos \theta$
- then discrete Fourier transform can be redefined

$$F(u) = \frac{1}{M} \sum_{x=0}^{M-1} f(x) [\cos 2\pi ux / M - j \sin 2\pi ux / M]$$

for $u = 0, 1, 2, \dots, M - 1$

- **Frequency (time) domain**: the domain (values of u) over which the values of $F(u)$ range; because u determines the frequency of the components of the transform.
- **Frequency (time) component**: each of the M terms of $F(u)$.



Signals in Frequency Domain

- $F(u)$ can be expressed in polar coordinates:

$$F(u) = |F(u)| e^{j\varphi(u)}$$

$$\text{where } |F(u)| = [R^2(u) + I^2(u)]^{\frac{1}{2}} \quad (\text{magnitude or spectrum})$$

$$\varphi(u) = \tan^{-1} \left[\frac{I(u)}{R(u)} \right] \quad (\text{phase angle or phase spectrum})$$

- $R(u)$: the real part of $F(u)$
- $I(u)$: the imaginary part of $F(u)$
- Power spectrum:

$$P(u) = |F(u)|^2 = R^2(u) + I^2(u)$$

Signals in Frequency Domain

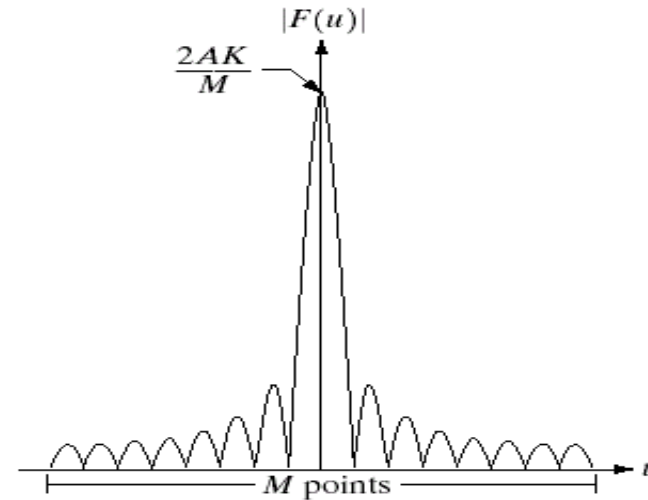
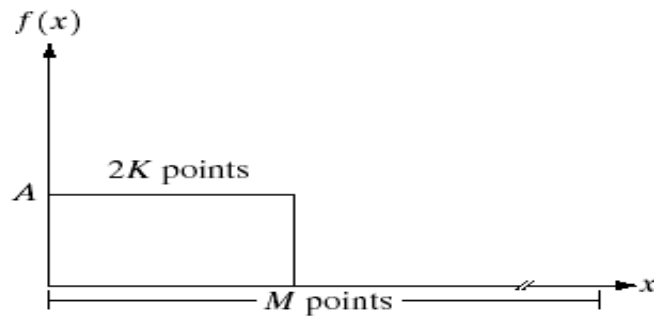
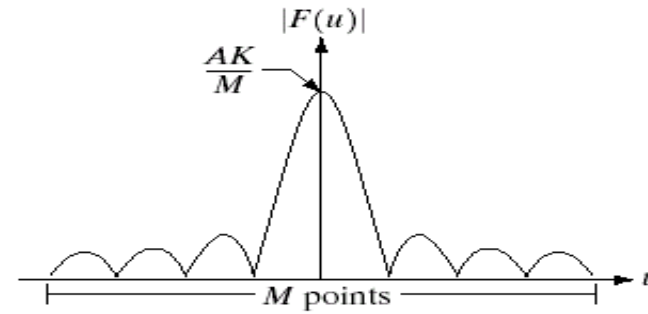
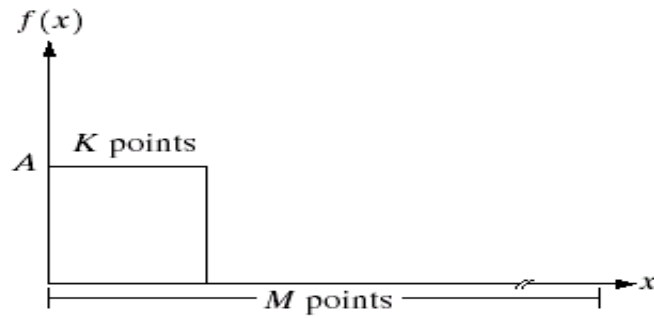

a	b
c	d

FIGURE 4.2 (a) A discrete function of M points, and (b) its Fourier spectrum. (c) A discrete function with twice the number of nonzero points, and (d) its Fourier spectrum.



Signals in Frequency Domain

- The **two-dimensional** Fourier transform and its inverse
 - Fourier transform (**discrete case**) DTC

$$F(u, v) = \frac{1}{MN} \sum_{x=0}^{M-1} \sum_{y=0}^{N-1} f(x, y) e^{-j2\pi(ux/M + vy/N)}$$

for $u = 0, 1, 2, \dots, M-1, v = 0, 1, 2, \dots, N-1$

- Inverse Fourier transform:

$$f(x, y) = \sum_{u=0}^{M-1} \sum_{v=0}^{N-1} F(u, v) e^{j2\pi(ux/M + vy/N)}$$

for $x = 0, 1, 2, \dots, M-1, y = 0, 1, 2, \dots, N-1$

- u, v : the transform or frequency variables
- x, y : the spatial or image variables



Signals in Frequency Domain

- We define the Fourier spectrum, phase angle, and power spectrum as follows:

$$|F(u, v)| = \left[R^2(u, v) + I^2(u, v) \right]^{\frac{1}{2}} \quad (\text{ spectrum })$$

$$\varphi(u, v) = \tan^{-1} \left[\frac{I(u, v)}{R(u, v)} \right] \quad (\text{ phase angle })$$

$$P(u, v) = |F(u, v)|^2 = R^2(u, v) + I^2(u, v) \quad (\text{ power spectrum })$$

- $R(u, v)$: the real part of $F(u, v)$
- $I(u, v)$: the imaginary part of $F(u, v)$



Signals in Frequency Domain

- Some properties of Fourier transform:

$$\mathfrak{F}\left[f(x, y)(-1)^{x+y}\right] = F\left(u - \frac{M}{2}, v - \frac{N}{2}\right) \quad (\text{shift})$$

$$F(0,0) = \frac{1}{MN} \sum_{x=0}^{M-1} \sum_{y=0}^{N-1} f(x, y) \quad (\text{average})$$

$$F(u, v) = F^*(-u, -v) \quad (\text{conjugate symmetric})$$

$$|F(u, v)| = |F(-u, -v)| \quad (\text{symmetric})$$

Signals in Frequency Domain

The 2D DFT $F(u,v)$ can be obtained by

1. taking the 1D DFT of every row of image $f(x,y)$, $F(u,y)$,
2. taking the 1D DFT of every column of $F(u,y)$

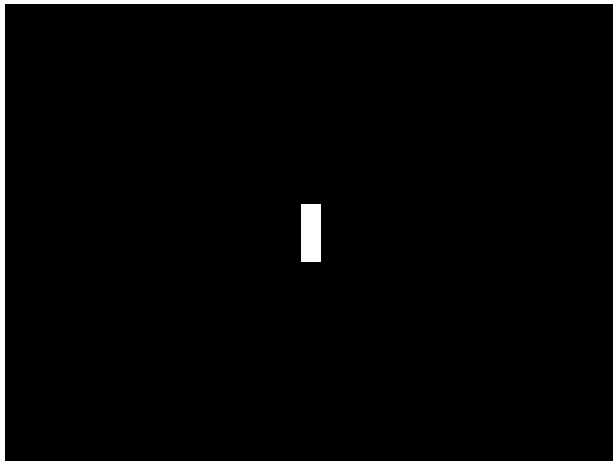

(a) $f(x,y)$

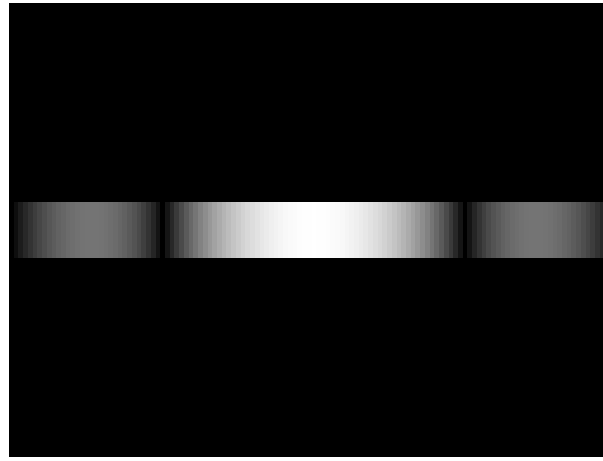

(b) $F(u,y)$

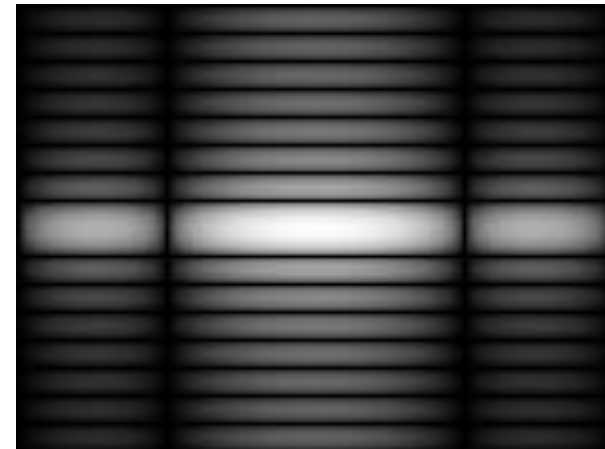

(c) $F(u,v)$

Signals in Frequency Domain

a b

FIGURE 4.3

(a) Image of a 20×40 white rectangle on a black background of size 512×512 pixels.

(b) Centered Fourier spectrum shown after application of the log transformation given in Eq. (3.2-2). Compare with Fig. 4.2.

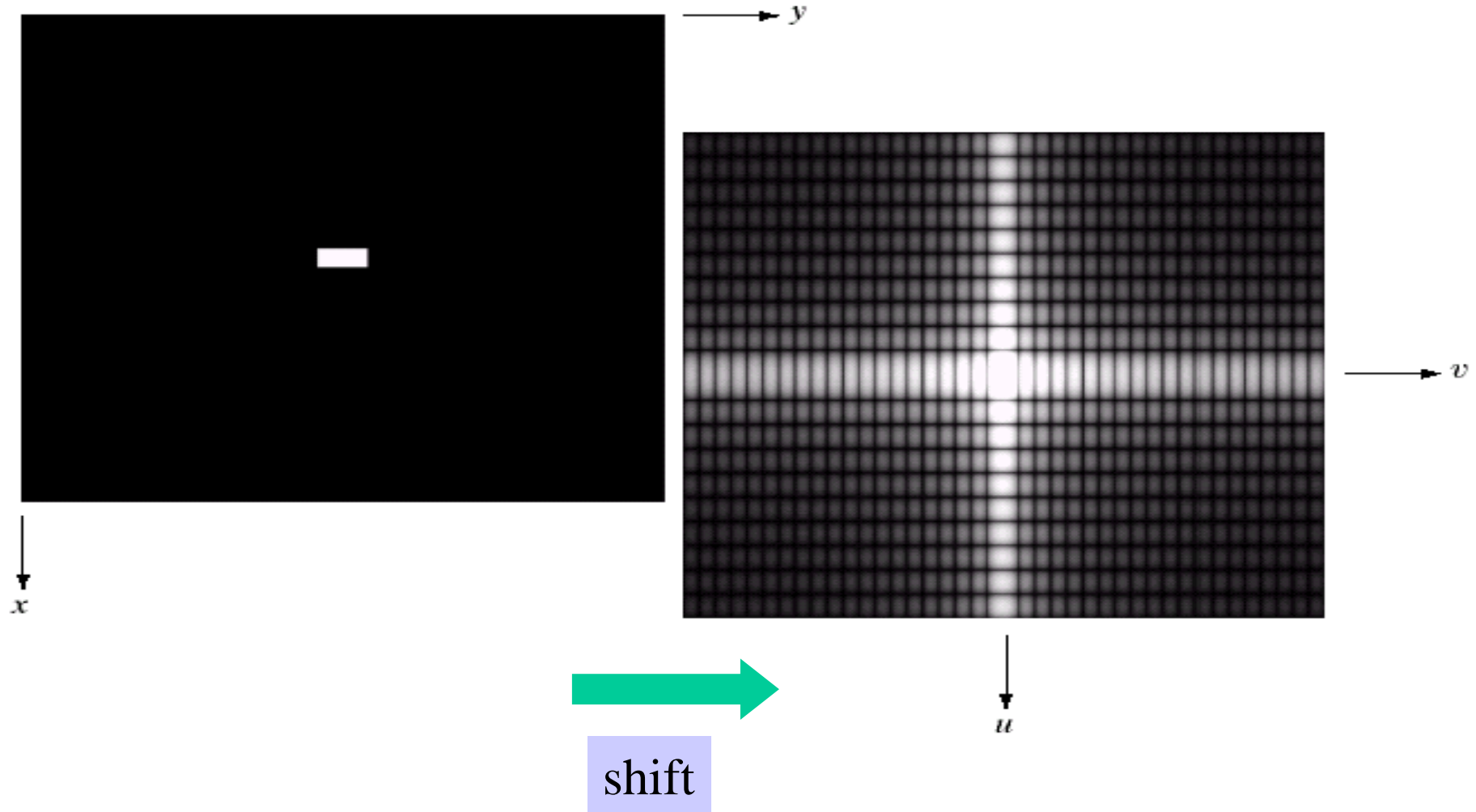



Signals in Frequency Domain

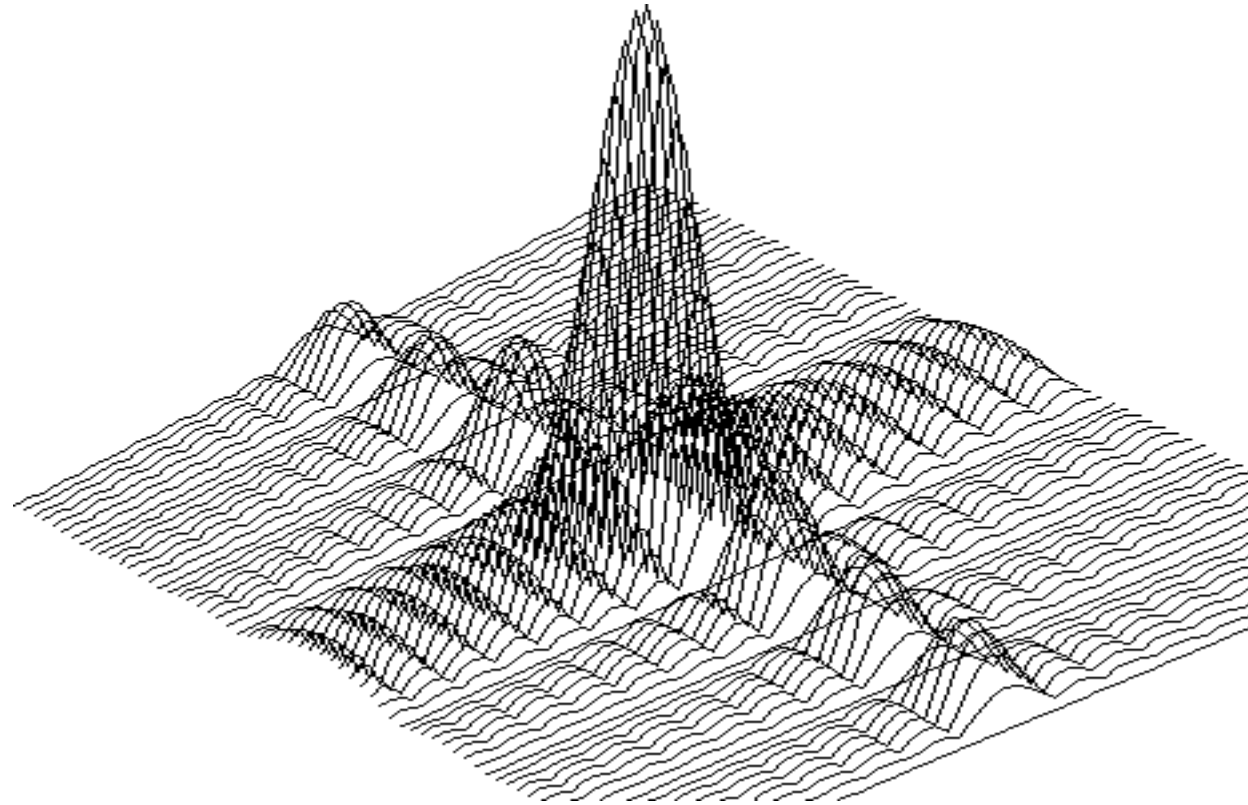



Signals in Frequency Domain

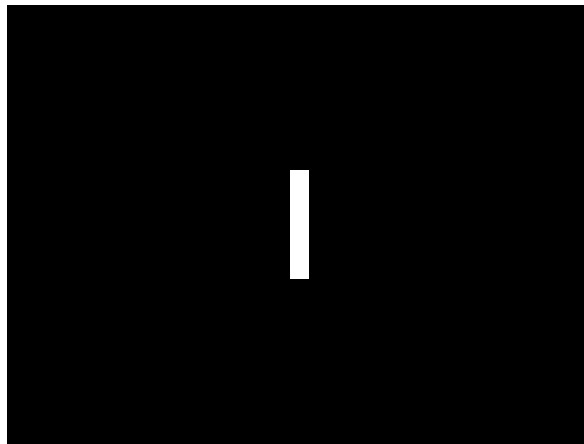

DFT

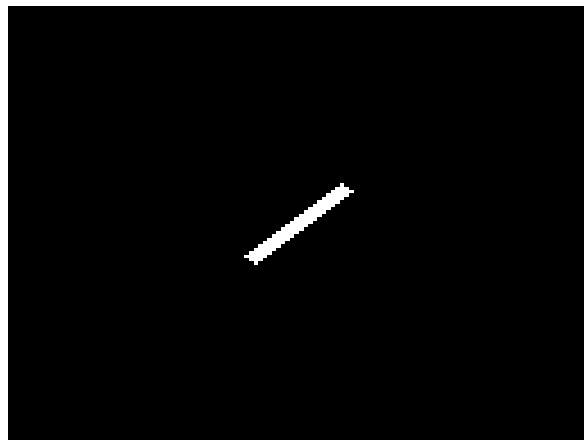
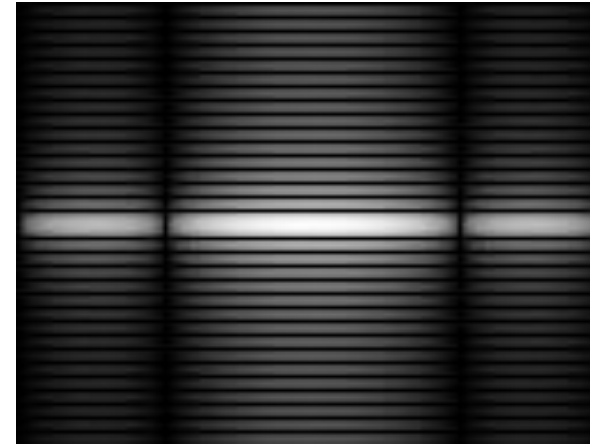

DFT

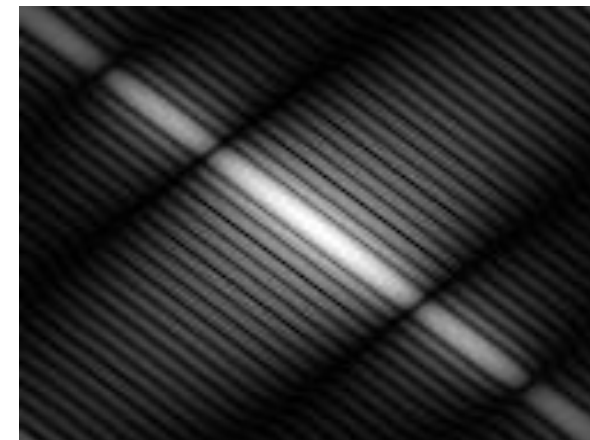

The Property of Two-Dimensional DFT

Linear Combination



Two-Dimensional DFT with Different Functions

Sine wave

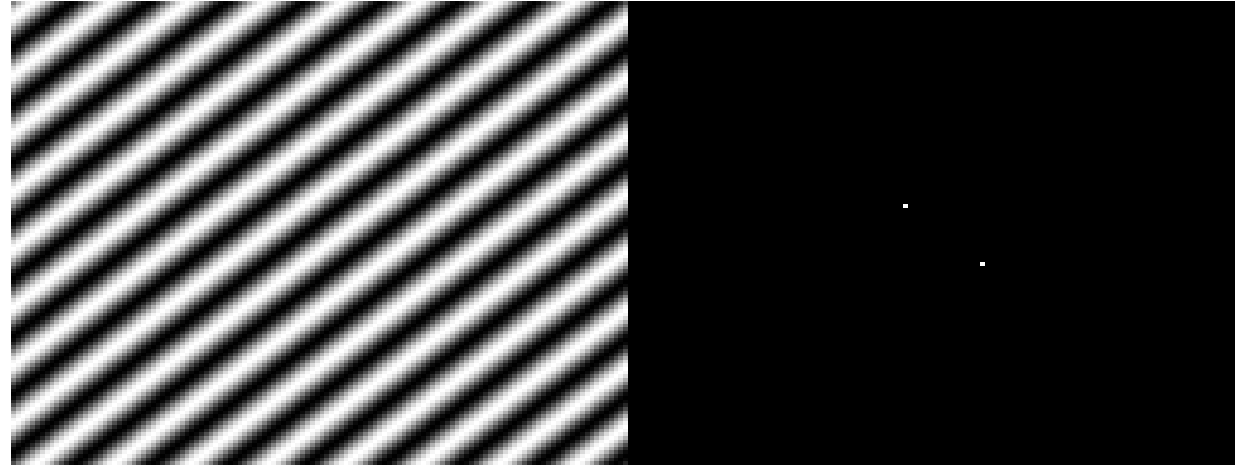

Its DFT

Rectangle

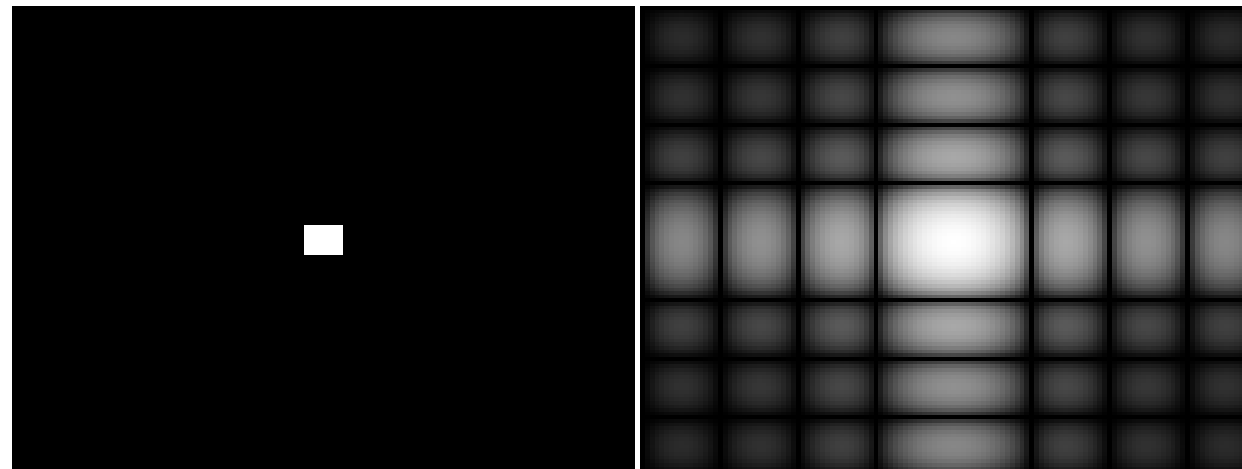

Its DFT

Two-Dimensional DFT with Different Functions

2D Gaussian
function

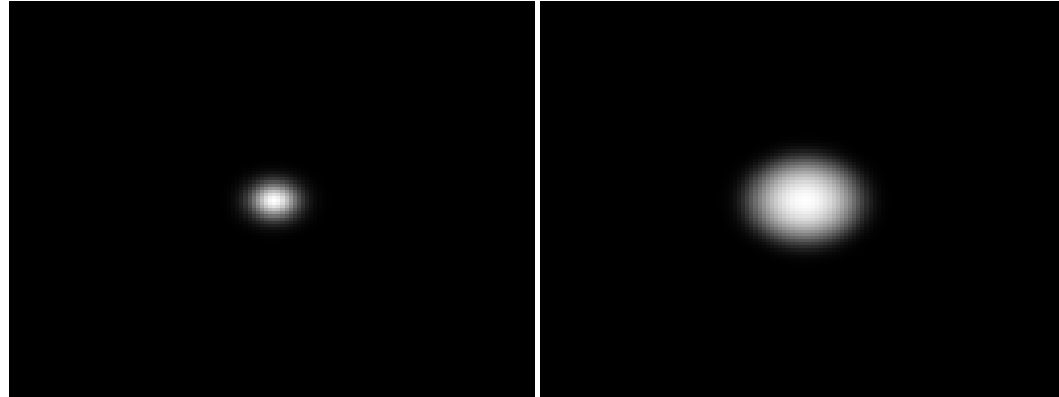

Its DFT

Impulses

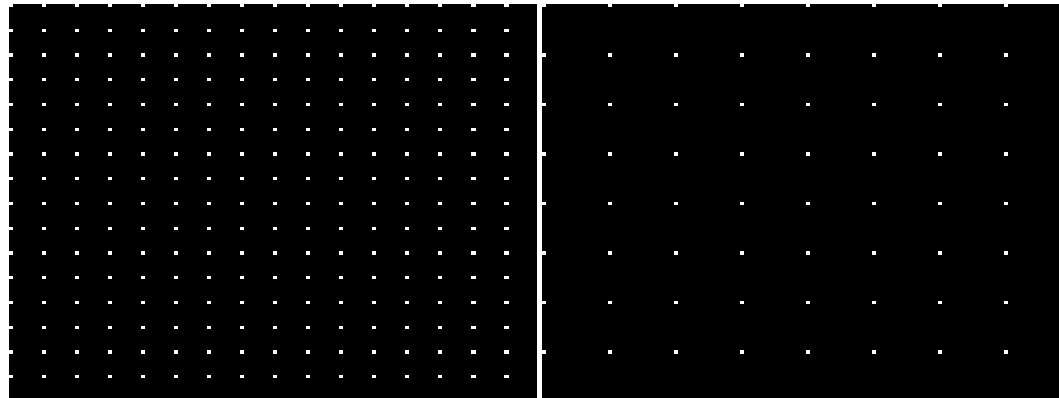

Its DFT

Filtering in the Frequency Domain

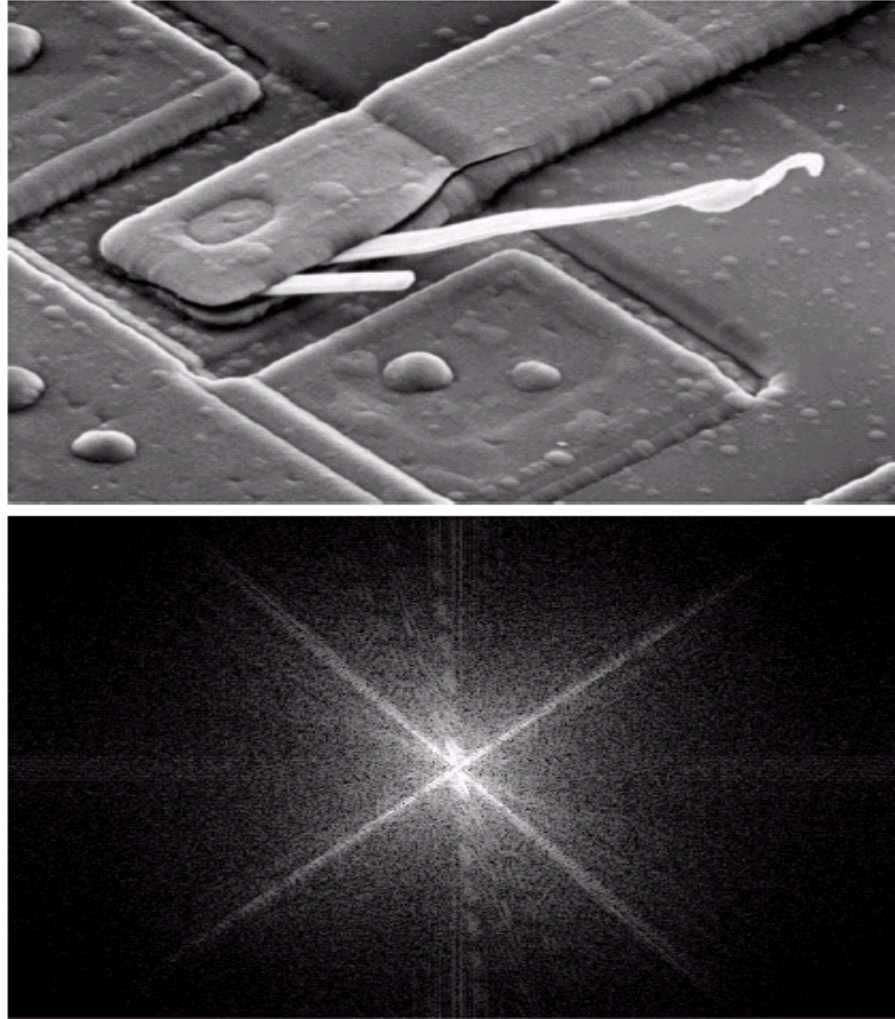

a
b

FIGURE 4.4

(a) SEM image of a damaged integrated circuit.

(b) Fourier spectrum of (a).

(Original image courtesy of Dr. J.

M. Hudak,

Brockhouse

Institute for

Materials

Research,

McMaster

University,

Hamilton,

Ontario, Canada.)

Basics of Filtering in the Frequency Domain

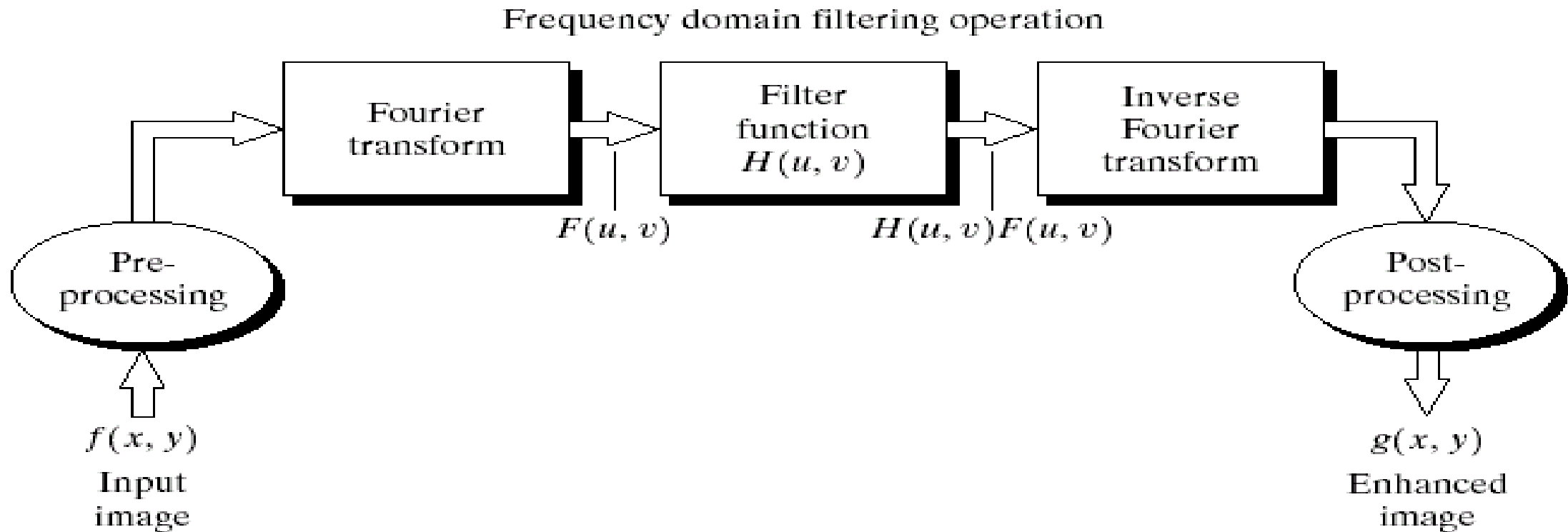

FIGURE 4.5 Basic steps for filtering in the frequency domain.

Some Basic Filters and Their Functions

- Multiply all values of $F(u,v)$ by the filter function (notch filter):

$$H(u,v) = \begin{cases} 0 & \text{if } (u,v) = (M/2, N/2) \\ 1 & \text{otherwise.} \end{cases}$$

- All this filter would do is set $F(0,0)$ to zero (force the average value of an image to zero) and leave all frequency components of the Fourier transform untouched.

FIGURE 4.6
Result of filtering the image in Fig. 4.4(a) with a notch filter that set to 0 the $F(0, 0)$ term in the Fourier transform.

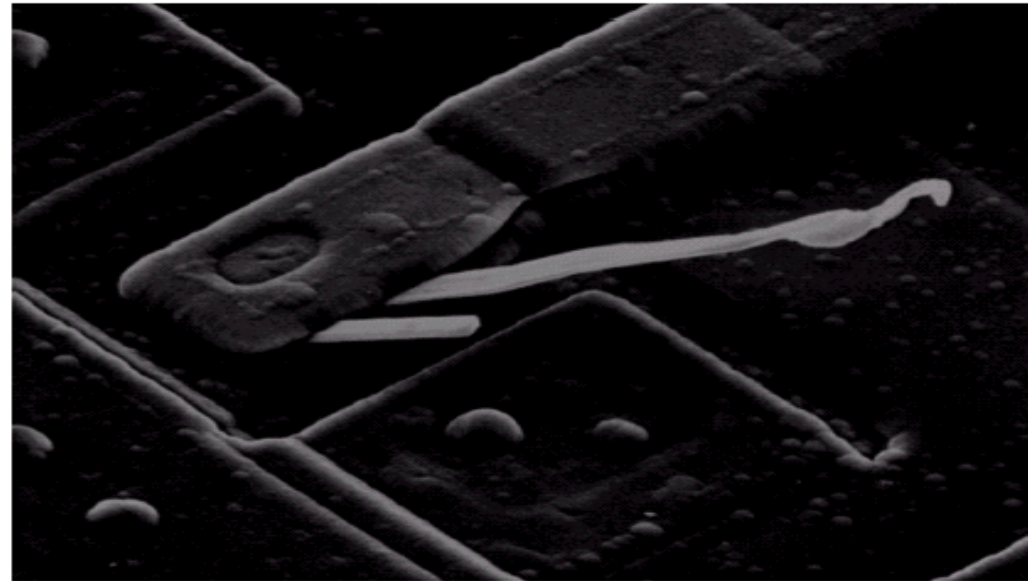

Some Basic Filters and Their Functions

Lowpass filter

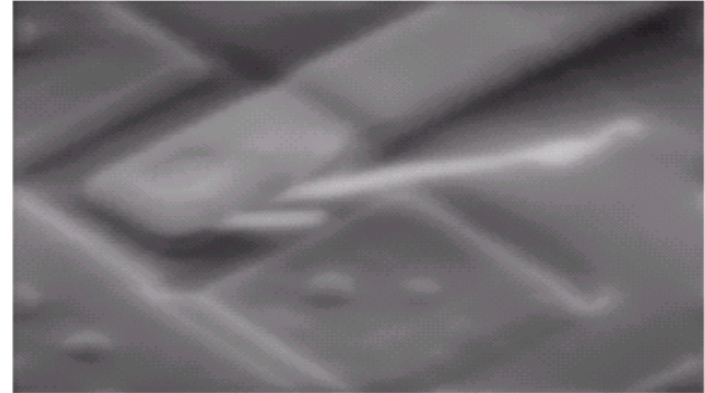
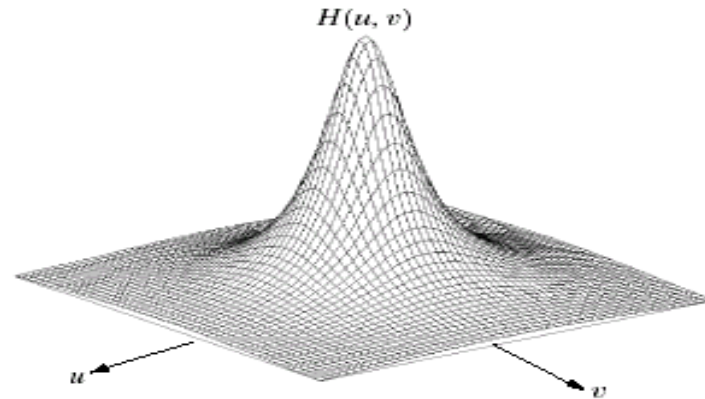

Highpass filter

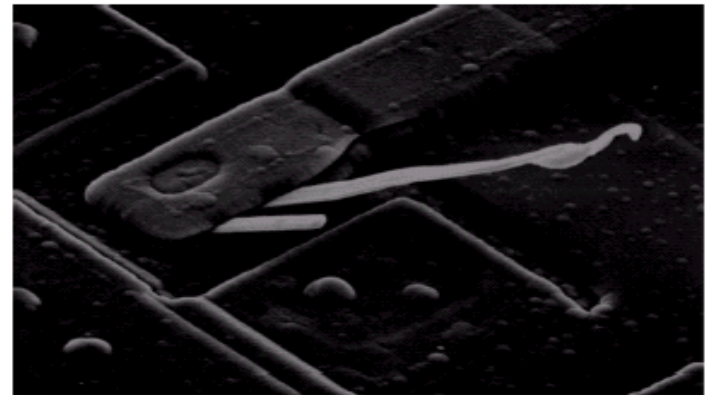
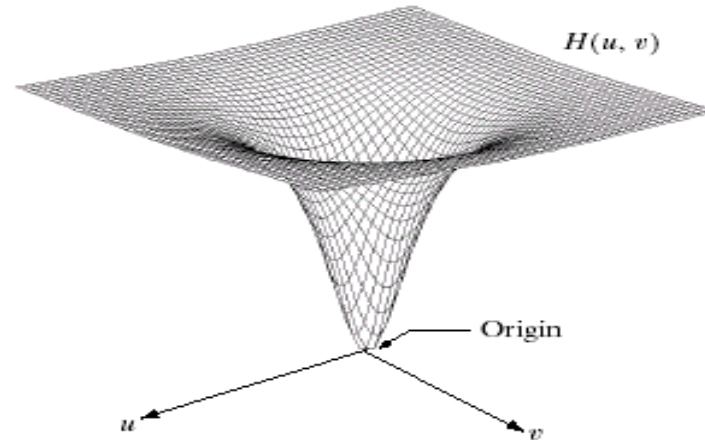

a	b
c	d

FIGURE 4.7 (a) A two-dimensional lowpass filter function. (b) Result of lowpass filtering the image in Fig. 4.4(a). (c) A two-dimensional highpass filter function. (d) Result of highpass filtering the image in Fig. 4.4(a).

Some Basic Filters and Their Functions

FIGURE 4.8
Result of highpass filtering the image in Fig. 4.4(a) with the filter in Fig. 4.7(c), modified by adding a constant of one-half the filter height to the filter function. Compare with Fig. 4.4(a).

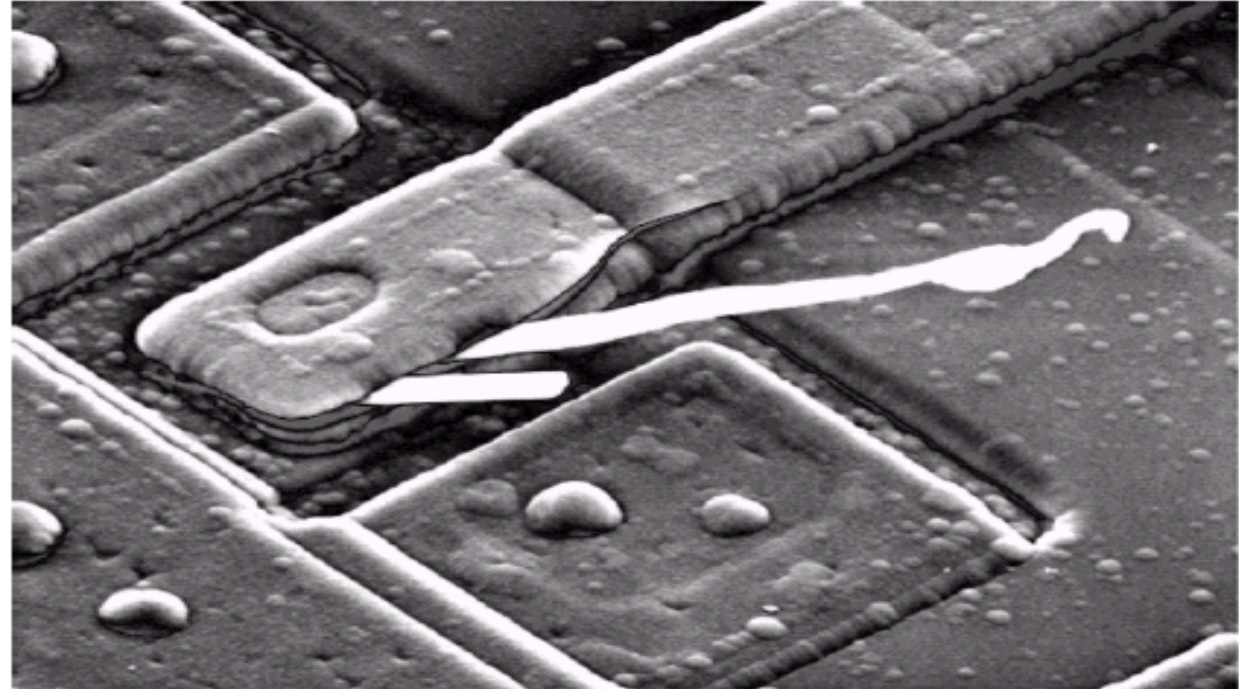



Correspondence between Filtering in the Spatial and Frequency Domain

- Convolution theorem:

- The discrete convolution of two functions $f(x,y)$ and $h(x,y)$ of size $M \times N$ is defined as

$$f(x,y) * h(x,y) = \frac{1}{MN} \sum_{m=0}^{M-1} \sum_{n=0}^{N-1} f(m,n) h(x-m, y-n)$$

- Let $F(u,v)$ and $H(u,v)$ denote the Fourier transforms of $f(x,y)$ and $h(x,y)$, then

$$f(x,y) * h(x,y) \Leftrightarrow F(u,v)H(u,v) \quad \text{Eq. (4.2-31)}$$

$$f(x,y)h(x,y) \Leftrightarrow F(u,v) * H(u,v) \quad \text{Eq. (4.2-32)}$$



Correspondence between Filtering in the Spatial and Frequency Domain

- $A\delta(x - x_0, y - y_0)$: an impulse function of strength A , located at coordinates (x_0, y_0)

$$\sum_{x=0}^{M-1} \sum_{y=0}^{N-1} s(x, y) A\delta(x - x_0, y - y_0) = As(x_0, y_0)$$

where $\sum_{x=0}^{M-1} \sum_{y=0}^{N-1} s(x, y)\delta(x, y) = s(0,0)$: a unit impulse located at the origin
 $\delta(x, y)$

- The Fourier transform of **a unit impulse at the origin** (Eq. (4.2-35)) :

$$F(u, v) = \frac{1}{MN} \sum_{x=0}^{M-1} \sum_{y=0}^{N-1} \delta(x, y) e^{-j2\pi(ux/M + vy/N)} = \frac{1}{MN}$$



Correspondence between Filtering in the Spatial and Frequency Domain

- Let $f(x, y) = \delta(x, y)$, then the convolution (Eq. (4.2-36))

$$\begin{aligned} f(x, y) * h(x, y) &= \frac{1}{MN} \sum_{m=0}^{M-1} \sum_{n=0}^{N-1} \delta(m, n) h(x - m, y - n) \\ &= \frac{1}{MN} h(x, y) \end{aligned}$$

- Combine Eqs. (4.2-35) (4.2-36) with Eq. (4.2-31), we obtain

$$\begin{aligned} f(x, y) * h(x, y) &\Leftrightarrow F(u, v) H(u, v) \\ \delta(x, y) * h(x, y) &\Leftrightarrow \mathcal{F}[\delta(x, y)] H(u, v) \\ \frac{1}{MN} h(x, y) &\Leftrightarrow \frac{1}{MN} H(u, v) \\ \xrightarrow{\text{green arrow}} & h(x, y) \Leftrightarrow H(u, v) \end{aligned}$$



Correspondence between Filtering in the Spatial and Frequency Domain

- Let $H(u)$ denote a frequency domain, Gaussian filter function given the equation

$$H(u) = Ae^{-u^2/2\sigma^2}$$

where σ : the standard deviation of the Gaussian curve.

- The corresponding filter in the spatial domain is

$$h(x) = \frac{1}{\sqrt{2\pi}\sigma} Ae^{-2\pi^2\sigma^2 x^2}$$

- Note: Both the forward and inverse Fourier transforms of a Gaussian function are **real Gaussian functions**.

Correspondence between Filtering in the Spatial and Frequency Domain

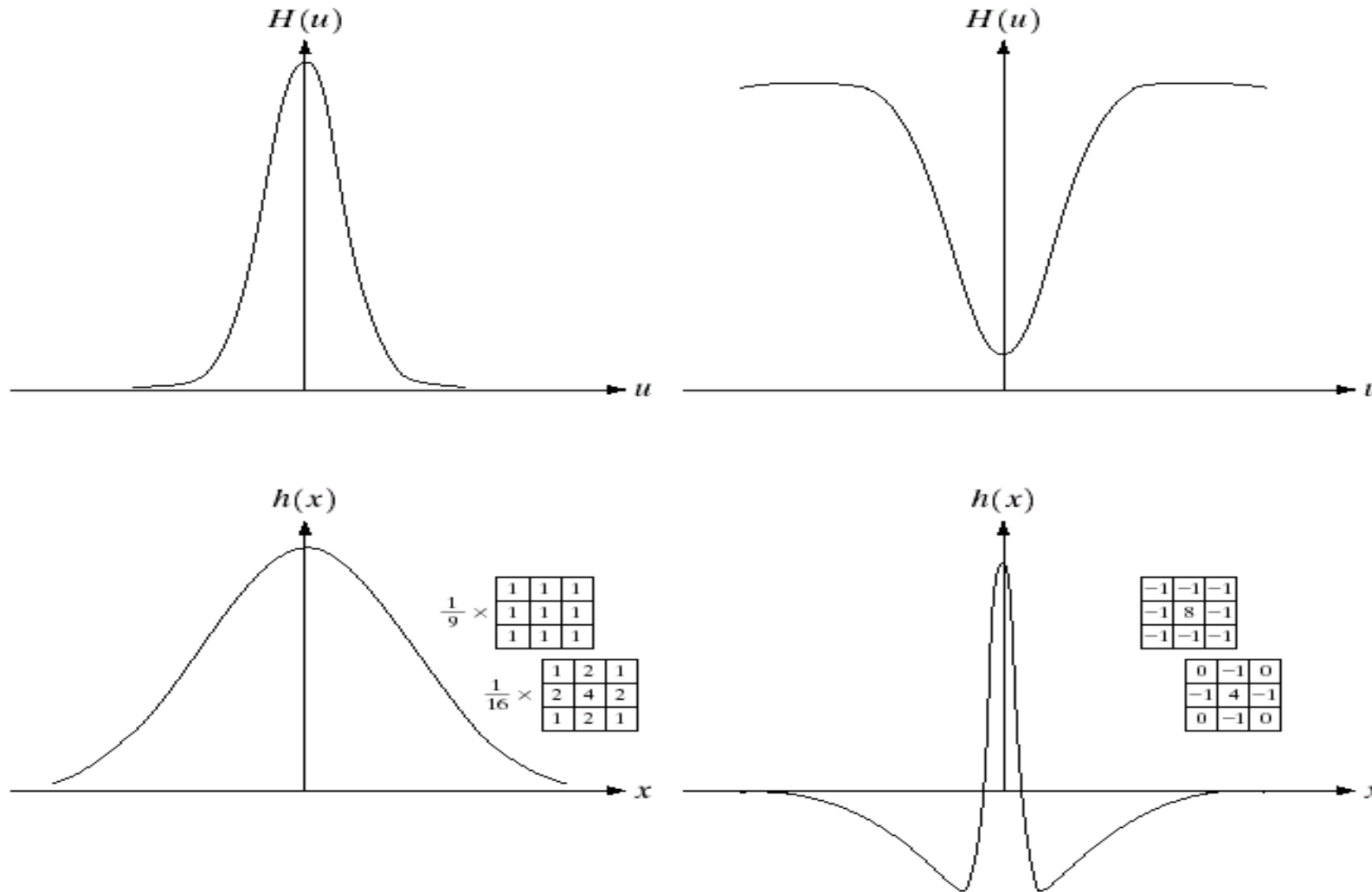

a	b
c	d

FIGURE 4.9
 (a) Gaussian frequency domain lowpass filter.
 (b) Gaussian frequency domain highpass filter.
 (c) Corresponding lowpass spatial filter.
 (d) Corresponding highpass spatial filter. The masks shown are used in Chapter 3 for lowpass and highpass filtering.



Correspondence between Filtering in the Spatial and Frequency Domain

- One very useful property of the Gaussian function is that both it and its Fourier transform are **real valued**; there are no complex values associated with them.
- In addition, the values are always **positive**. So, if we convolve an image with a Gaussian function, there will never be any negative output values to deal with.
- There is also an important relationship between the widths of a Gaussian function and its Fourier transform. If we make **the width of the function smaller, the width of the Fourier transform gets larger**. This is controlled by the variance parameter σ^2 in the equations.
- These properties make the Gaussian filter very useful for **lowpass filtering** an image. The amount of blur is controlled by σ^2 . It can be implemented in either the spatial or frequency domain.
- Other filters besides lowpass can also be implemented by using two different sized Gaussian functions.



Smoothing Frequency-Domain Filters

- The basic model for filtering in the frequency domain

$$G(u, v) = H(u, v)F(u, v)$$

where $F(u, v)$: the Fourier transform of the image to be smoothed

$H(u, v)$: a filter transfer function

- Smoothing is fundamentally a lowpass operation in the frequency domain.
- There are several standard forms of lowpass filters (LPF).
 - Ideal lowpass filter
 - Butterworth lowpass filter
 - Gaussian lowpass filter



Ideal Lowpass Filters (ILPFs)

- The simplest lowpass filter is a filter that “cuts off” all high-frequency components of the Fourier transform that are at a distance greater than a specified distance D_0 from the origin of the transform.
- The transfer function of an ideal lowpass filter

$$H(u,v) = \begin{cases} 1 & \text{if } D(u,v) \leq D_0 \\ 0 & \text{if } D(u,v) > D_0 \end{cases}$$

where $D(u,v)$: the distance from point (u,v) to the center of the frequency rectangle

$$D(u,v) = \left[(u - M/2)^2 + (v - N/2)^2 \right]^{1/2}$$

Ideal Lowpass Filters (ILPFs)

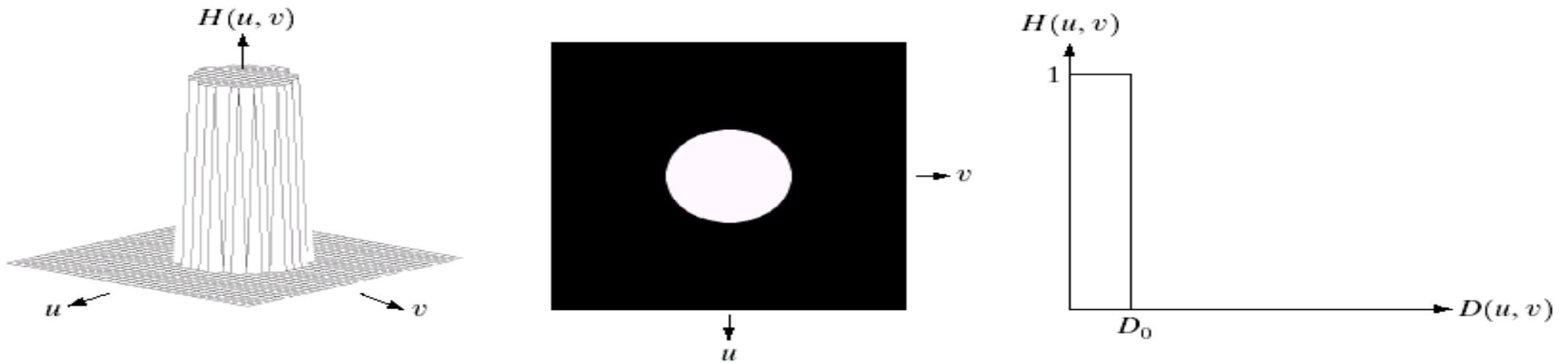

a b c

FIGURE 4.10 (a) Perspective plot of an ideal lowpass filter transfer function. (b) Filter displayed as an image. (c) Filter radial cross section.

Ideal Lowpass Filters (ILPFs)

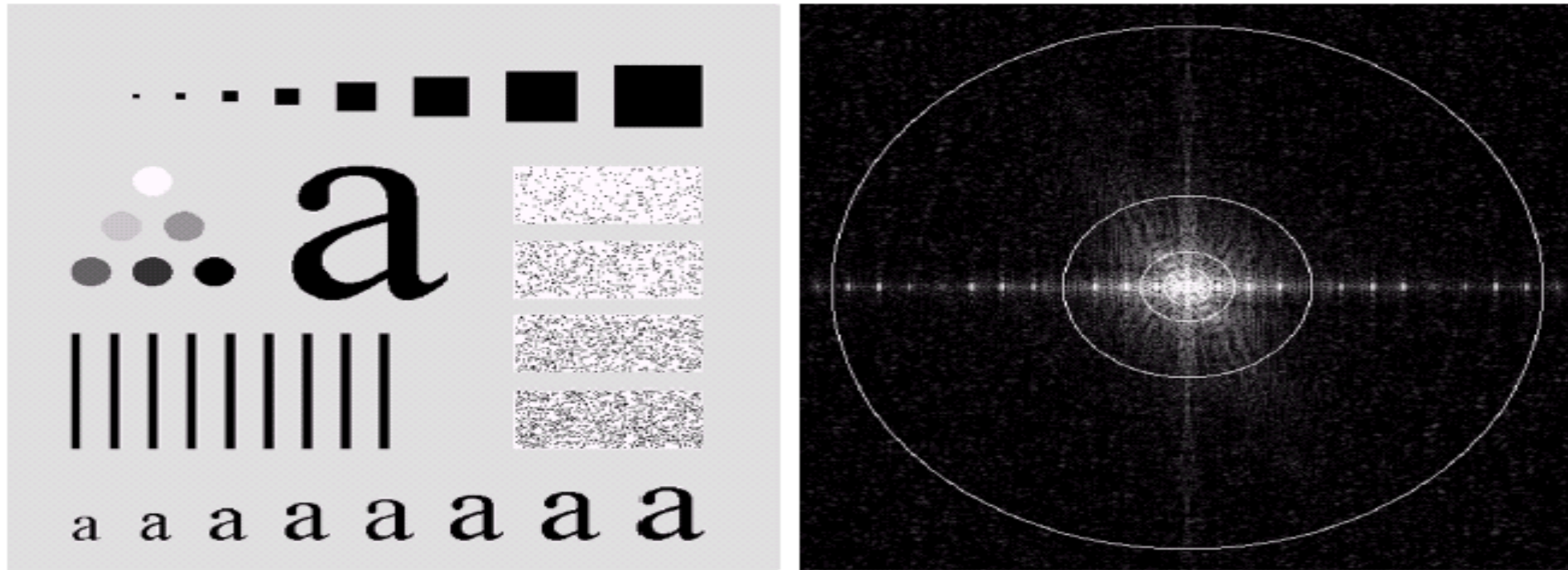

a b

FIGURE 4.11 (a) An image of size 500×500 pixels and (b) its Fourier spectrum. The superimposed circles have radii values of 5, 15, 30, 80, and 230, which enclose 92.0, 94.6, 96.4, 98.0, and 99.5% of the image power, respectively.

Ideal Lowpass Filters



a	b
c	d
e	f

FIGURE 4.12 (a) Original image. (b)–(f) Results of ideal lowpass filtering with cutoff frequencies set at radii values of 5, 15, 30, 80, and 230, as shown in Fig. 4.11(b). The power removed by these filters was 8, 5.4, 3.6, 2, and 0.5% of the total, respectively.

Butterworth Lowpass Filters (BLPFs) with order n

$$H(u, v) = \frac{1}{1 + [D(u, v) / D_0]^{2n}}$$

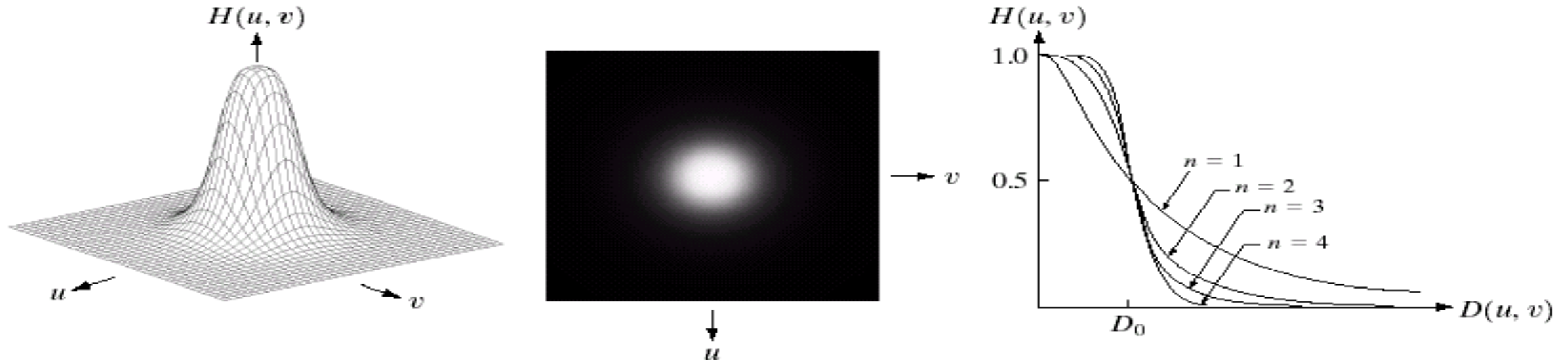

a b c

FIGURE 4.14 (a) Perspective plot of a Butterworth lowpass filter transfer function. (b) Filter displayed as an image. (c) Filter radial cross sections of orders 1 through 4.

Butterworth Lowpass Filters (BLPFs)

$$n=2$$

$D_0=5, 15, 30, 80, \text{ and } 230$



a b
c d
e f

FIGURE 4.15 (a) Original image. (b)–(f) Results of filtering with BLPFs of order 2, with cutoff frequencies at radii of 5, 15, 30, 80, and 230, as shown in Fig. 4.11(b). Compare with Fig. 4.12.

Butterworth Lowpass Filters (BLPFs)

Spatial Representation

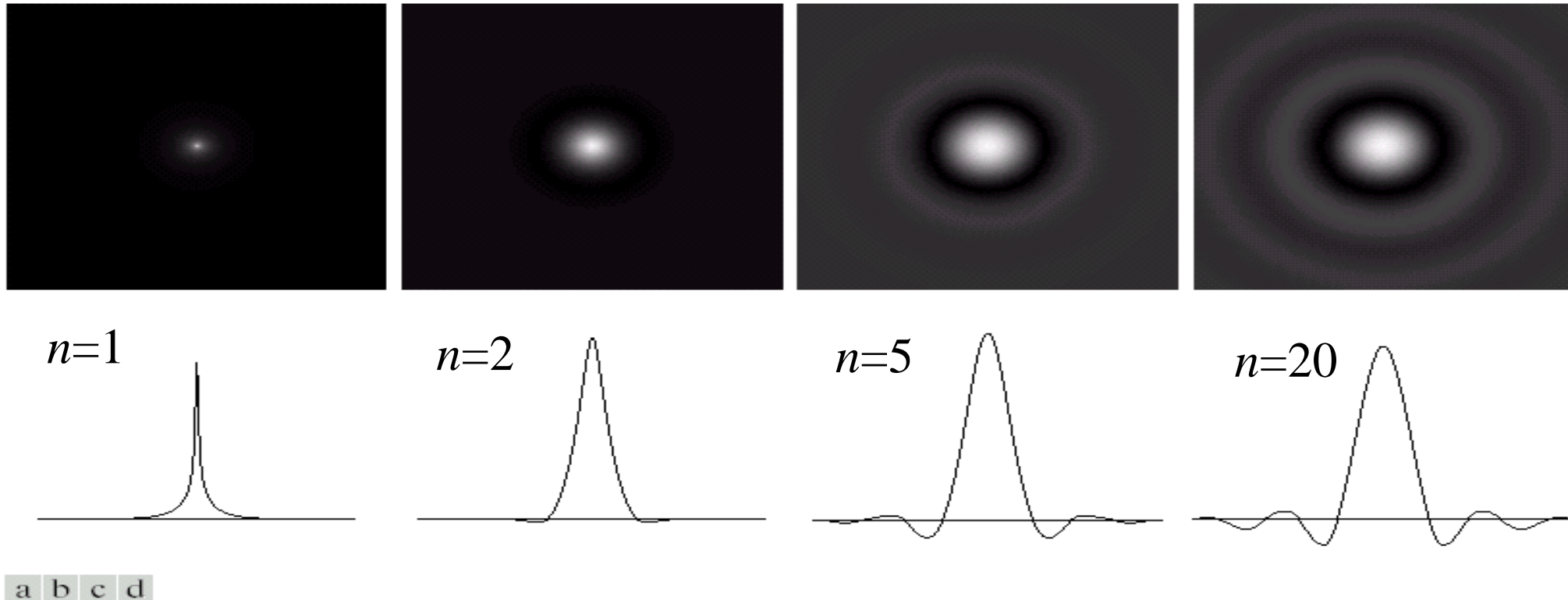
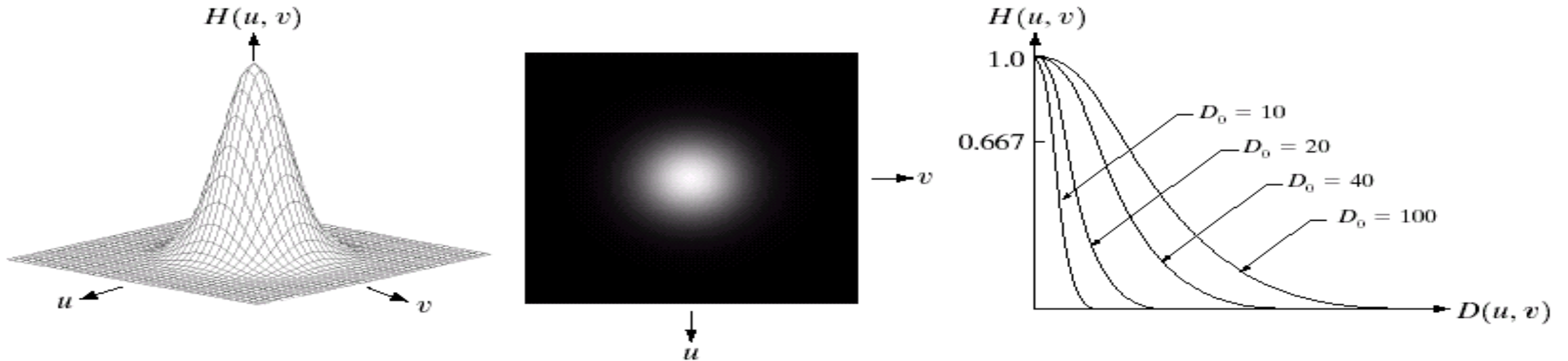

FIGURE 4.16 (a)–(d) Spatial representation of BLPFs of order 1, 2, 5, and 20, and corresponding gray-level profiles through the center of the filters (all filters have a cutoff frequency of 5). Note that ringing increases as a function of filter order.

Gaussian Lowpass Filters (FLPFs)

$$H(u, v) = e^{-D^2(u, v) / 2D_0^2}$$



a b c

FIGURE 4.17 (a) Perspective plot of a GLPF transfer function. (b) Filter displayed as an image. (c) Filter radial cross sections for various values of D_0 .

Gaussian Lowpass Filters (FLPFs)

$D_0=5,15,30,80, and $230$$



FIGURE 4.18 (a) Original image. (b)–(f) Results of filtering with Gaussian lowpass filters with cutoff frequencies set at radii values of 5, 15, 30, 80, and 230, as shown in Fig. 4.11(b). Compare with Figs. 4.12 and 4.15.

a b
c d
e f

Additional Examples of Lowpass Filtering

a b

FIGURE 4.19

(a) Sample text of poor resolution (note broken characters in magnified view).
(b) Result of filtering with a GLPF (broken character segments were joined).

Historically, certain computer programs were written using only two digits rather than four to define the applicable year. Accordingly, the company's software may recognize a date using "00" as 1900 rather than the year 2000.

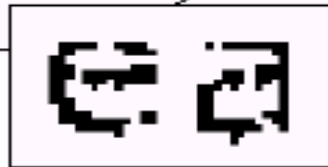

Historically, certain computer programs were written using only two digits rather than four to define the applicable year. Accordingly, the company's software may recognize a date using "00" as 1900 rather than the year 2000.

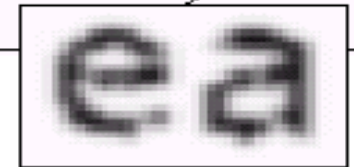

Additional Examples of Lowpass Filtering



a b c

FIGURE 4.20 (a) Original image (1028×732 pixels). (b) Result of filtering with a GLPF with $D_0 = 100$. (c) Result of filtering with a GLPF with $D_0 = 80$. Note reduction in skin fine lines in the magnified sections of (b) and (c).

Sharpening Frequency Domain Filter

$$H_{hp}(u, v) = 1 - H_{lp}(u, v)$$

Ideal highpass filter

$$H(u, v) = \begin{cases} 0 & \text{if } D(u, v) \leq D_0 \\ 1 & \text{if } D(u, v) > D_0 \end{cases}$$

Butterworth highpass filter

$$H(u, v) = \frac{1}{1 + [D_0 / D(u, v)]^{2n}}$$

Gaussian highpass filter

$$H(u, v) = 1 - e^{-D^2(u, v) / 2D_0^2}$$

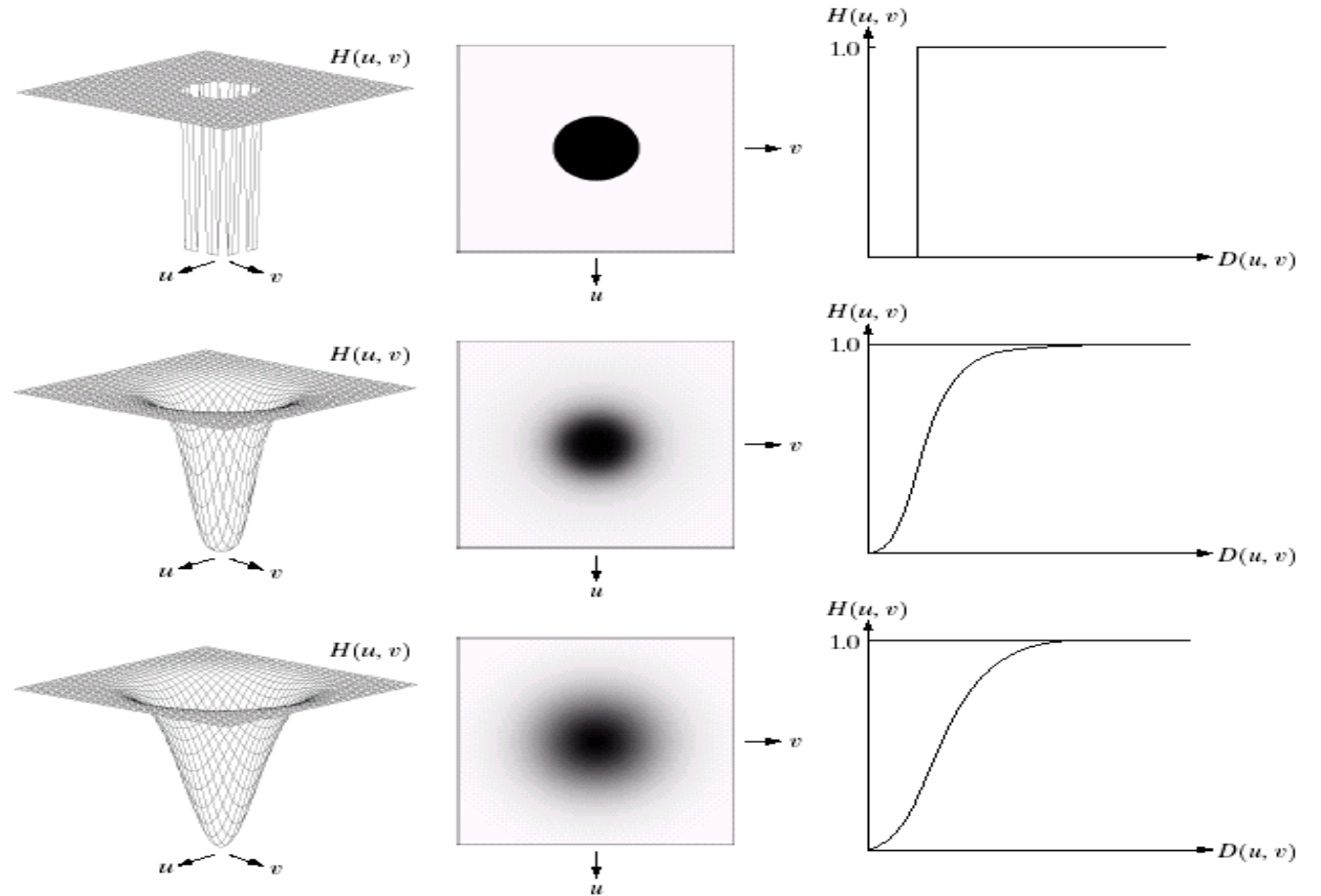

a b c
d e f
g h i

FIGURE 4.22 Top row: Perspective plot, image representation, and cross section of a typical ideal highpass filter. Middle and bottom rows: The same sequence for typical Butterworth and Gaussian highpass filters.

Highpass Filters

Spatial Representations

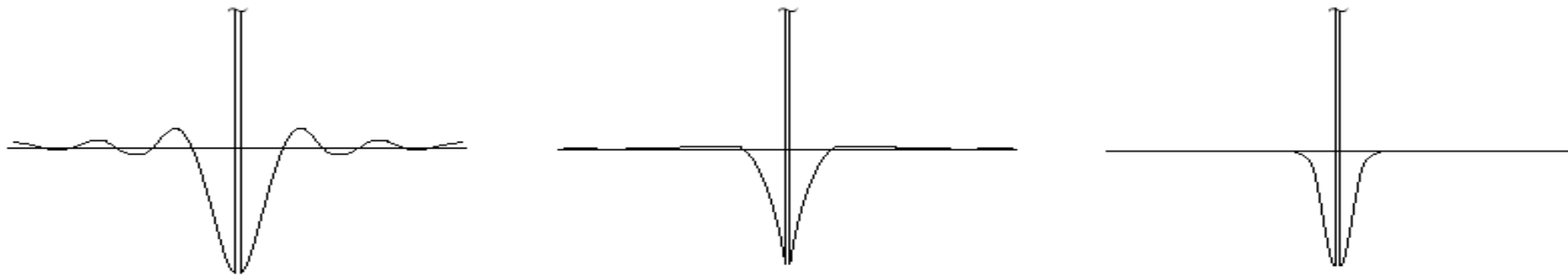

a b c

FIGURE 4.23 Spatial representations of typical (a) ideal, (b) Butterworth, and (c) Gaussian frequency domain highpass filters, and corresponding gray-level profiles.

Ideal Highpass Filters

$$H(u,v) = \begin{cases} 0 & \text{if } D(u,v) \leq D_0 \\ 1 & \text{if } D(u,v) > D_0 \end{cases}$$



a b c

FIGURE 4.24 Results of ideal highpass filtering the image in Fig. 4.11(a) with $D_0 = 15, 30,$ and $80,$ respectively. Problems with ringing are quite evident in (a) and (b).

Butterworth Highpass Filters

$$H(u,v) = \frac{1}{1 + [D_0 / D(u,v)]^{2n}}$$

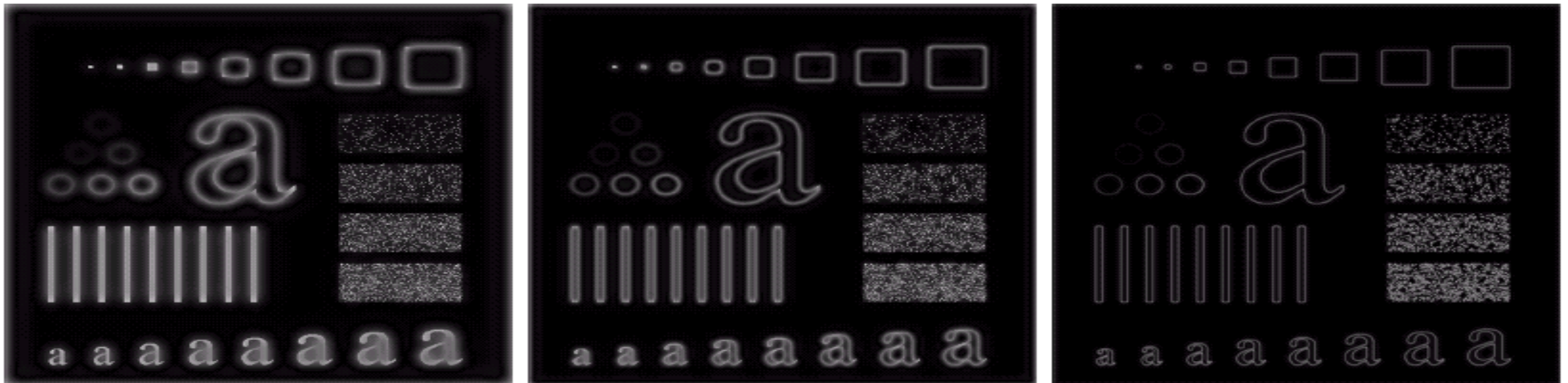

a b c

FIGURE 4.25 Results of highpass filtering the image in Fig. 4.11(a) using a BHPF of order 2 with $D_0 = 15$, 30, and 80, respectively. These results are much smoother than those obtained with an ILPF.

Gaussian Highpass Filters

$$H(u, v) = 1 - e^{-D^2(u, v) / 2D_0^2}$$

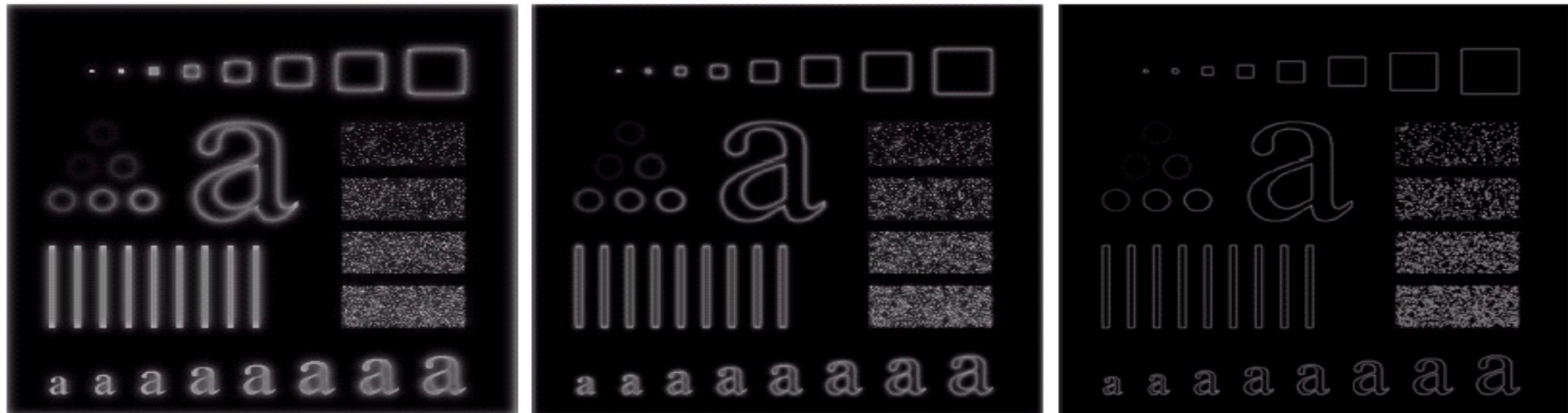

a b c

FIGURE 4.26 Results of highpass filtering the image of Fig. 4.11(a) using a GHPF of order 2 with $D_0 = 15$, 30, and 80, respectively. Compare with Figs. 4.24 and 4.25.

The Laplacian in the Frequency Domain

- The Laplacian filter

$$H(u, v) = -(u^2 + v^2)$$

- Shift the center:

$$H(u, v) = - \left[\left(u - \frac{M}{2} \right)^2 + \left(v - \frac{N}{2} \right)^2 \right]$$

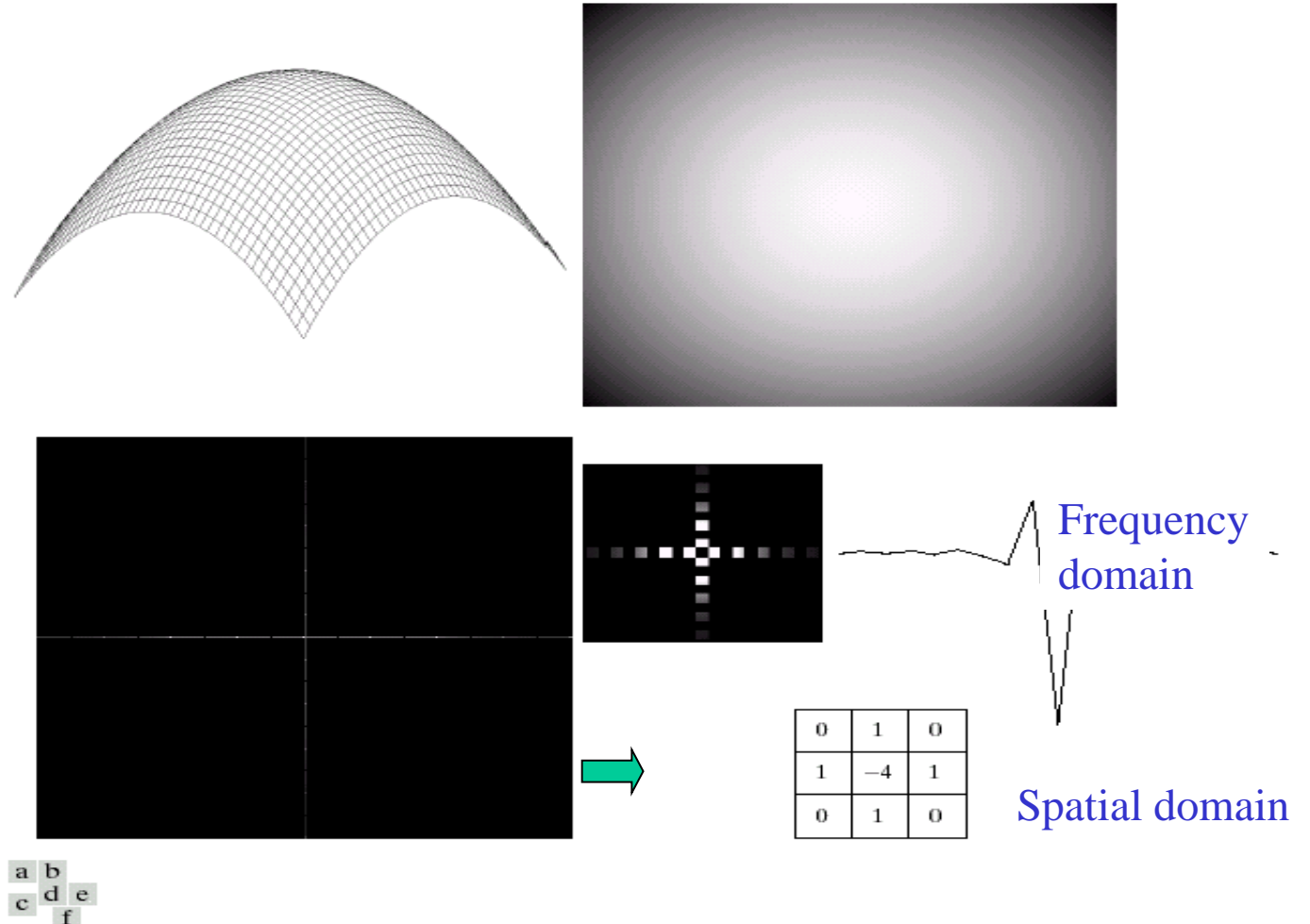
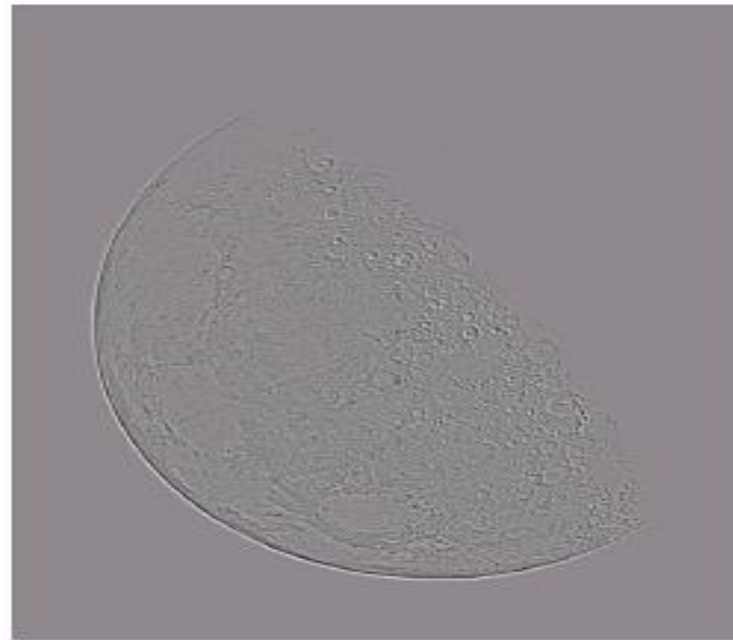
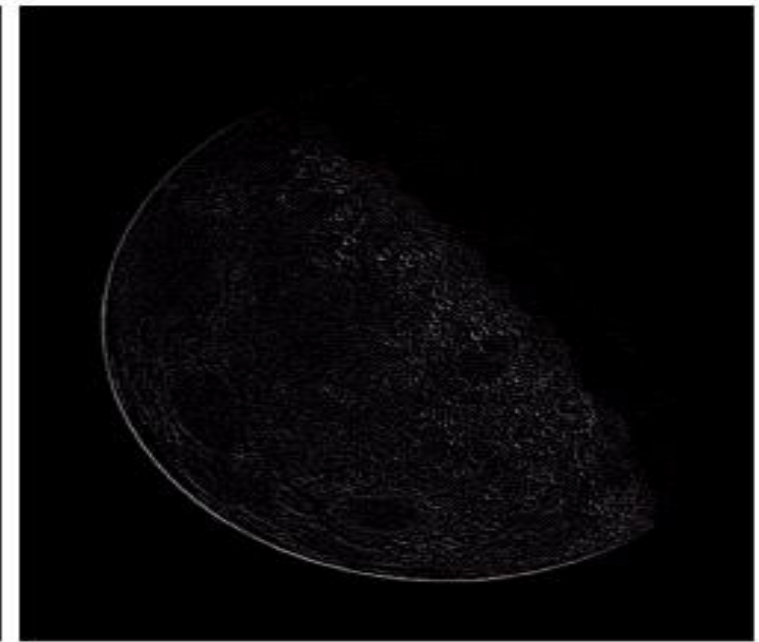

FIGURE 4.27 (a) 3-D plot of Laplacian in the frequency domain. (b) Image representation of (a). (c) Laplacian in the spatial domain obtained from the inverse DFT of (b). (d) Zoomed section of the origin of (c). (e) Gray-level profile through the center of (d). (f) Laplacian mask used in Section 3.7.

a	b
c	d

FIGURE 4.28
(a) Image of the North Pole of the moon.
(b) Laplacian filtered image.
(c) Laplacian image scaled.
(d) Image enhanced by using Eq. (4.4-12).
(Original image courtesy of NASA.)



Some Additional Properties of the 2D Fourier Transform

- Periodicity, symmetry, and back-to-back properties

a b
c d

FIGURE 4.34
 (a) Fourier spectrum showing back-to-back half periods in the interval $[0, M - 1]$.
 (b) Shifted spectrum showing a full period in the same interval.
 (c) Fourier spectrum of an image, showing the same back-to-back properties as (a), but in two dimensions.
 (d) Centered Fourier spectrum.

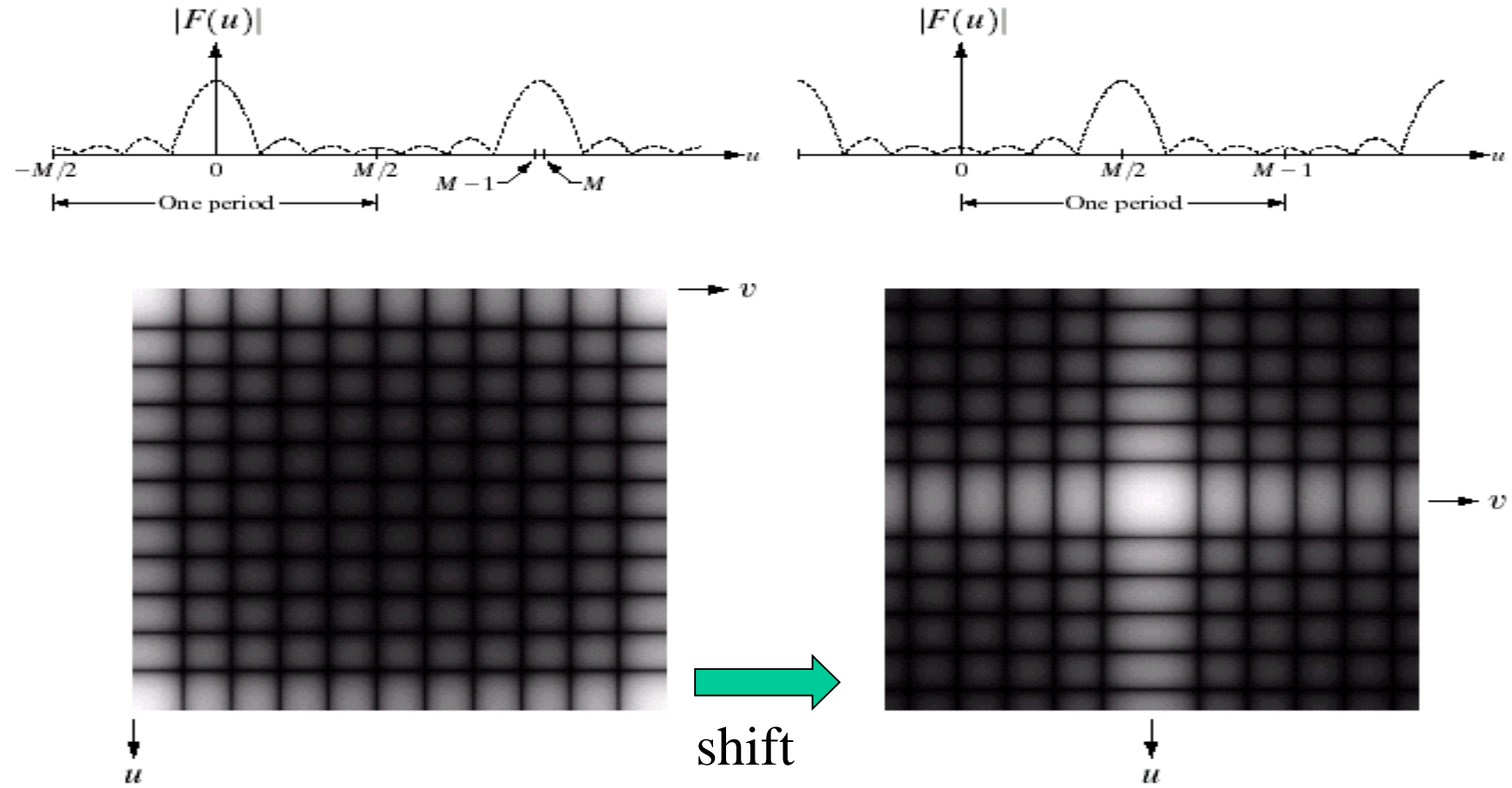



Some Additional Properties of the 2D Fourier Transform

- Separability

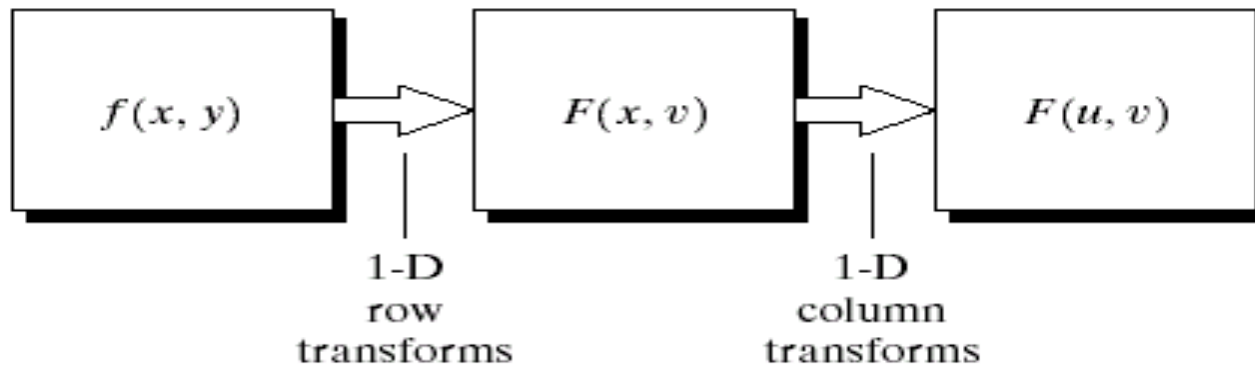

FIGURE 4.35
Computation of the 2-D Fourier transform as a series of 1-D transforms.



Summary of Some Important Properties of the 2-D Fourier Transform

TABLE 4.1

Summary of some important properties of the 2-D Fourier transform.

Property	Expression(s)
Fourier transform	$F(u, v) = \frac{1}{MN} \sum_{x=0}^{M-1} \sum_{y=0}^{N-1} f(x, y) e^{-j2\pi(ux/M + vy/N)}$
Inverse Fourier transform	$f(x, y) = \sum_{u=0}^{M-1} \sum_{v=0}^{N-1} F(u, v) e^{j2\pi(ux/M + vy/N)}$
Polar representation	$F(u, v) = F(u, v) e^{-j\phi(u, v)}$
Spectrum	$ F(u, v) = [R^2(u, v) + I^2(u, v)]^{1/2}, \quad R = \text{Real}(F) \text{ and } I = \text{Imag}(F)$
Phase angle	$\phi(u, v) = \tan^{-1} \left[\frac{I(u, v)}{R(u, v)} \right]$
Power spectrum	$P(u, v) = F(u, v) ^2$
Average value	$\bar{f}(x, y) = F(0, 0) = \frac{1}{MN} \sum_{x=0}^{M-1} \sum_{y=0}^{N-1} f(x, y)$
Translation	$f(x, y) e^{j2\pi(u_0 x/M + v_0 y/N)} \Leftrightarrow F(u - u_0, v - v_0)$ $f(x - x_0, y - y_0) \Leftrightarrow F(u, v) e^{-j2\pi(ux_0/M + vy_0/N)}$ <p>When $x_0 = u_0 = M/2$ and $y_0 = v_0 = N/2$, then</p> $f(x, y) (-1)^{x+y} \Leftrightarrow F(u - M/2, v - N/2)$ $f(x - M/2, y - N/2) \Leftrightarrow F(u, v) (-1)^{u+v}$



Summary of Some Important Properties of the 2-D Fourier Transform

Conjugate symmetry	$F(u, v) = F^*(-u, -v)$ $ F(u, v) = F(-u, -v) $
Differentiation	$\frac{\partial^n f(x, y)}{\partial x^n} \Leftrightarrow (ju)^n F(u, v)$ $(-jx)^n f(x, y) \Leftrightarrow \frac{\partial^n F(u, v)}{\partial u^n}$
Laplacian	$\nabla^2 f(x, y) \Leftrightarrow -(u^2 + v^2)F(u, v)$
Distributivity	$\mathfrak{S}[f_1(x, y) + f_2(x, y)] = \mathfrak{S}[f_1(x, y)] + \mathfrak{S}[f_2(x, y)]$ $\mathfrak{S}[f_1(x, y) \cdot f_2(x, y)] \neq \mathfrak{S}[f_1(x, y)] \cdot \mathfrak{S}[f_2(x, y)]$
Scaling	$af(x, y) \Leftrightarrow aF(u, v), f(ax, by) \Leftrightarrow \frac{1}{ ab } F(u/a, v/b)$
Rotation	$x = r \cos \theta \quad y = r \sin \theta \quad u = \omega \cos \varphi \quad v = \omega \sin \varphi$ $f(r, \theta + \theta_0) \Leftrightarrow F(\omega, \varphi + \theta_0)$
Periodicity	$F(u, v) = F(u + M, v) = F(u, v + N) = F(u + M, v + N)$ $f(x, y) = f(x + M, y) = f(x, y + N) = f(x + M, y + N)$
Separability	See Eqs. (4.6-14) and (4.6-15). Separability implies that we can compute the 2-D transform of an image by first computing 1-D transforms along each row of the image, and then computing a 1-D transform along each column of this intermediate result. The reverse, columns and then rows, yields the same result.

TABLE 4.1
(continued)



Summary of Some Important Properties of the 2-D Fourier Transform

Property	Expression(s)
Computation of the inverse Fourier transform using a forward transform algorithm	$\frac{1}{MN} f^*(x, y) = \frac{1}{MN} \sum_{u=0}^{M-1} \sum_{v=0}^{N-1} F^*(u, v) e^{-j2\pi(ux/M + vy/N)}$ <p>This equation indicates that inputting the function $F^*(u, v)$ into an algorithm designed to compute the forward transform (right side of the preceding equation) yields $f^*(x, y)/MN$. Taking the complex conjugate and multiplying this result by MN gives the desired inverse.</p>
Convolution [†]	$f(x, y) * h(x, y) = \frac{1}{MN} \sum_{m=0}^{M-1} \sum_{n=0}^{N-1} f(m, n) h(x - m, y - n)$
Correlation [†]	$f(x, y) \circ h(x, y) = \frac{1}{MN} \sum_{m=0}^{M-1} \sum_{n=0}^{N-1} f^*(m, n) h(x + m, y + n)$
Convolution theorem [†]	$f(x, y) * h(x, y) \Leftrightarrow F(u, v) H(u, v);$ $f(x, y) h(x, y) \Leftrightarrow F(u, v) * H(u, v)$
Correlation theorem [†]	$f(x, y) \circ h(x, y) \Leftrightarrow F^*(u, v) H(u, v);$ $f^*(x, y) h(x, y) \Leftrightarrow F(u, v) \circ H(u, v)$

TABLE 4.1
(continued)



Summary of Some Important Properties of the 2-D Fourier Transform

Some useful FT pairs:

TABLE 4.1
(continued)

<i>Impulse</i>	$\delta(x, y) \Leftrightarrow 1$
<i>Gaussian</i>	$A\sqrt{2\pi}\sigma e^{-2\pi^2\sigma^2(x^2+y^2)} \Leftrightarrow Ae^{-(u^2+v^2)/2\sigma^2}$
<i>Rectangle</i>	$\text{rect}[a, b] \Leftrightarrow ab \frac{\sin(\pi ua)}{(\pi ua)} \frac{\sin(\pi vb)}{(\pi vb)} e^{-j\pi(ua+vb)}$
<i>Cosine</i>	$\cos(2\pi u_0 x + 2\pi v_0 y) \Leftrightarrow \frac{1}{2} [\delta(u + u_0, v + v_0) + \delta(u - u_0, v - v_0)]$
<i>Sine</i>	$\sin(2\pi u_0 x + 2\pi v_0 y) \Leftrightarrow j \frac{1}{2} [\delta(u + u_0, v + v_0) - \delta(u - u_0, v - v_0)]$

[†] Assumes that functions have been extended by zero padding.

Low and High Pass filtering

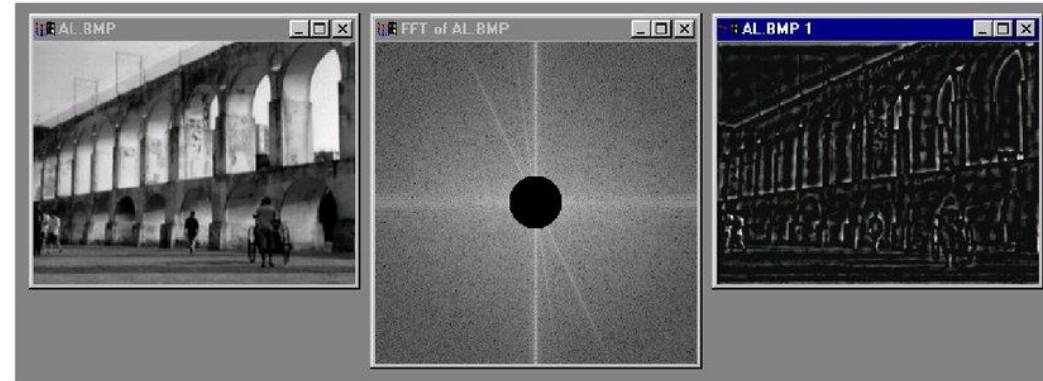
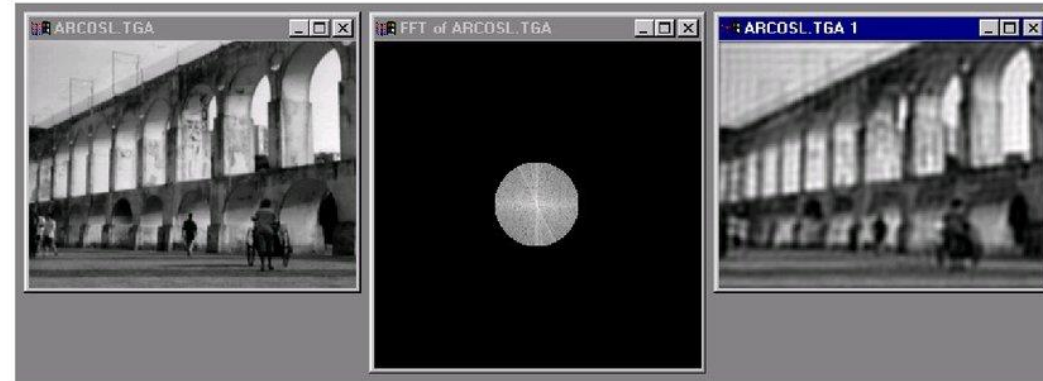

Chapter 4

END OF LECTURE